

Solutions to AIEEE - 2008

AIEEE-2008, PAPER(C-5)

Note: (i) The test is of 3 hours duration.

(ii) The test consists of 105 questions of 3 marks each. The maximum marks are 315.

(iii) There are three parts in the question paper. The distribution of marks subjectwise in each part is as under for each correct response.

Part A – Mathematics (105 marks) – 35 Questions

Part B – Chemistry (105 marks) – 35 Questions

Part C – Physics (105 marks) – 35 Questions

(iv) Candidates will be awarded three marks each for indicated correct response of each question. One mark will be deducted for indicated incorrect response of each question. No deduction from the total score will be made if no response is indicated for an item in the Answer Sheet.

Mathematics

PART – A

1. AB is a vertical pole with B at the ground level and A at the top. A man finds that the angle of elevation of the point A from a certain point C on the ground is 60° . He moves away from the pole along the line BC to a point D such that $CD = 7$ m. From D the angle of elevation of the point A is 45° . Then the height of the pole is

(1) $\frac{7\sqrt{3}}{2} \cdot \frac{1}{\sqrt{3}-1}$ m

(2) $\frac{7\sqrt{3}}{2} \cdot (\sqrt{3}+1)$ m

(3) $\frac{7\sqrt{3}}{2} \cdot (\sqrt{3}-1)$ m

(4) $\frac{7\sqrt{3}}{2} \cdot \frac{1}{\sqrt{3}+1}$

Sol:

(2)

$$BD = AB = 7 + x$$

$$\text{Also } AB = x \tan 60^\circ = x\sqrt{3}$$

$$\therefore x\sqrt{3} = 7 + x$$

$$x = \frac{7}{\sqrt{3}-1}$$

$$AB = \frac{7\sqrt{3}}{2}(\sqrt{3}+1).$$

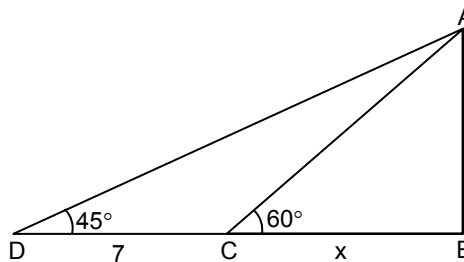

2. It is given that the events A and B are such that $P(A) = \frac{1}{4}$, $P\left(\frac{A}{B}\right) = \frac{1}{2}$ and $P\left(\frac{B}{A}\right) = \frac{2}{3}$. Then P(B) is

(1) $\frac{1}{6}$

(2) $\frac{1}{3}$

(3) $\frac{2}{3}$

(4) $\frac{1}{2}$

Sol:

(2)

$$\frac{P(A \cap B)}{P(B)} = \frac{1}{2}, \quad \frac{P(A \cap B)}{P(A)} = \frac{2}{3}$$

$$\text{Hence } \frac{P(A)}{P(B)} = \frac{3}{4}. \quad (\text{But } P(A) = 1/4)$$

$$\Rightarrow P(B) = \frac{1}{3}.$$

Solutions to AIEEE - 2008

3. A die is thrown. Let A be the event that the number obtained is greater than 3. Let B be the event that the number obtained is less than 5. Then $P(A \cup B)$ is

- (1) $\frac{3}{5}$ (2) 0
(3) 1 (4) $\frac{2}{5}$

Sol: (3)

$$A = \{4, 5, 6\}, B = \{1, 2, 3, 4\}.$$

$$\text{Obviously } P(A \cup B) = 1.$$

4. A focus of an ellipse is at the origin. The directrix is the line $x = 4$ and the eccentricity is $1/2$. Then the length of the semi-major axis is

- (1) $\frac{8}{3}$ (2) $\frac{2}{3}$
(3) $\frac{4}{3}$ (4) $\frac{5}{3}$

Sol: (1)

Major axis is along x-axis.

$$\frac{a}{e} - ae = 4$$

$$a\left(2 - \frac{1}{2}\right) = 4$$

$$a = \frac{8}{3}.$$

5. A parabola has the origin as its focus and the line $x = 2$ as the directrix. Then the vertex of the parabola is at

- (1) (0, 2) (2) (1, 0)
(3) (0, 1) (4) (2, 0)

Sol: (2)

Vertex is (1, 0)

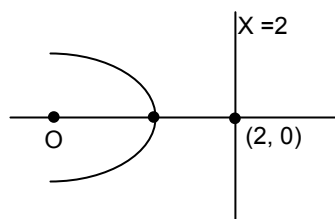

6. The point diametrically opposite to the point P (1, 0) on the circle $x^2 + y^2 + 2x + 4y - 3 = 0$ is

- (1) (3, -4) (2) (-3, 4)
(3) (-3, -4) (4) (3, 4)

Sol: (3)

Centre (-1, -2)

Let (α, β) is the required point

$$\frac{\alpha + 1}{2} = -1 \text{ and } \frac{\beta + 0}{2} = -2.$$

7. Let $f : N \rightarrow Y$ be a function defined as $f(x) = 4x + 3$, where $Y = \{y \in N : y = 4x + 3 \text{ for some } x \in N\}$. Show that f is invertible and its inverse is

- (1) $g(y) = \frac{3y + 4}{3}$ (2) $g(y) = 4 + \frac{y + 3}{4}$
(3) $g(y) = \frac{y + 3}{4}$ (4) $g(y) = \frac{y - 3}{4}$

Sol: (4)
Function is increasing

$$x = \frac{y-3}{4} = g(y).$$

8. The conjugate of a complex number is $\frac{1}{i-1}$. Then the complex number is

(1) $\frac{-1}{i-1}$

(2) $\frac{1}{i+1}$

(3) $\frac{-1}{i+1}$

(4) $\frac{1}{i-1}$

Sol: (3)
Put $-i$ in place of i

Hence $\frac{-1}{i+1}$.

9. Let R be the real line. Consider the following subsets of the plane $R \times R$.
 $S = \{(x, y) : y = x + 1 \text{ and } 0 < x < 2\}$, $T = \{(x, y) : x - y \text{ is an integer}\}$. Which one of the following is true?

- (1) neither S nor T is an equivalence relation on R
 (2) both S and T are equivalence relations on R
 (3) S is an equivalence relation on R but T is not
 (4) T is an equivalence relation on R but S is not

Sol: (4)
 $T = \{(x, y) : x - y \in I\}$
 as $0 \in I$ T is a reflexive relation.
 If $x - y \in I \Rightarrow y - x \in I$
 $\therefore T$ is symmetrical also
 If $x - y = I_1$ and $y - z = I_2$
 Then $x - z = (x - y) + (y - z) = I_1 + I_2 \in I$
 $\therefore T$ is also transitive.
 Hence T is an equivalence relation.
 Clearly $x \neq x + 1 \Rightarrow (x, x) \notin S$
 $\therefore S$ is not reflexive.

10. The perpendicular bisector of the line segment joining $P(1, 4)$ and $Q(k, 3)$ has y -intercept -4 . Then a possible value of k is

(1) 1

(2) 2

(3) -2

(4) -4

Sol: (4)
Slope of bisector = $k - 1$

Middle point = $\left(\frac{k+1}{2}, \frac{7}{2}\right)$

Equation of bisector is

$$y - \frac{7}{2} = (k - 1) \left(x - \frac{k+1}{2}\right)$$

Put $x = 0$ and $y = -4$.

$$\Rightarrow k = \pm 4.$$

11. The solution of the differential equation $\frac{dy}{dx} = \frac{x+y}{x}$ satisfying the condition $y(1) = 1$ is

(1) $y = \ln x + x$

(2) $y = x \ln x + x^2$

(3) $y = xe^{(x-1)}$

(4) $y = x \ln x + x$

Sol: (4)
 $y = vx$

Solutions to AIEEE - 2008

$$\frac{dy}{dx} = v + x \frac{dv}{dx}$$

$$v + x \frac{dv}{dx} = 1 + v$$

$$\Rightarrow dv = \frac{dx}{x}$$

$$\therefore v = \log x + c$$

$$\Rightarrow \frac{y}{x} = \log x + c$$

Since, $y(1) = 1$, we have

$$y = x \log x + x$$

12. The mean of the numbers $a, b, 8, 5, 10$ is 6 and the variance is 6.80. Then which one of the following gives possible values of a and b ?

(1) $a = 0, b = 7$

(2) $a = 5, b = 2$

(3) $a = 1, b = 6$

(4) $a = 3, b = 4$

Sol: (4)

Mean of $a, b, 8, 5, 10$ is 6

$$\Rightarrow \frac{a + b + 8 + 5 + 10}{5} = 6$$

$$\Rightarrow a + b = 7 \quad \dots (1)$$

Given that Variance is 6.8

$$\therefore \text{Variance} = \frac{\sum (X_i - A)^2}{n}$$

$$= \frac{(a-6)^2 + (b-6)^2 + 4 + 1 + 16}{5} = 6.8$$

$$\Rightarrow a^2 + b^2 = 25$$

$$a^2 + (7-a)^2 = 25 \quad (\text{Using (1)})$$

$$\Rightarrow a^2 - 7a + 12 = 0$$

$$\therefore a = 4, 3 \text{ and } b = 3, 4.$$

13. The vector $\vec{a} = \alpha \hat{i} + 2\hat{j} + \beta \hat{k}$ lies in the plane of the vectors $\vec{b} = \hat{i} + \hat{j}$ and $\vec{c} = \hat{j} + \hat{k}$ and bisects the angle between \vec{b} and \vec{c} . Then which one of the following gives possible values of α and β ?

(1) $\alpha = 2, \beta = 2$

(2) $\alpha = 1, \beta = 2$

(3) $\alpha = 2, \beta = 1$

(4) $\alpha = 1, \beta = 1$

Sol: (4)

$$\vec{a} = \lambda(\vec{b} + \vec{c})$$

$$\Rightarrow \alpha \hat{i} + 2\hat{j} + \beta \hat{k} = \lambda \left(\frac{\hat{i} + 2\hat{j} + \hat{k}}{\sqrt{2}} \right)$$

$$\lambda = \sqrt{2}\alpha \text{ and } \lambda = \sqrt{2} \text{ and } \lambda = \sqrt{2}\beta$$

$$\Rightarrow \alpha = 1 \text{ and } \beta = 1.$$

14. The non-zero vectors \vec{a}, \vec{b} and \vec{c} are related by $\vec{a} = 8\vec{b}$ and $\vec{c} = -7\vec{b}$. Then the angle between \vec{a} and \vec{c} is

(1) 0

(2) $\pi/4$

(3) $\pi/2$

(4) π

Sol: (4)

$$\text{Since } \vec{a} = 8\vec{b}$$

$$\vec{c} = -7\vec{b}$$

$\therefore \vec{a}$ and \vec{b} are like vectors and \vec{b} and \vec{c} are unlike.

$\Rightarrow \vec{a}$ and \vec{c} will be unlike

Solutions to AIEEE - 2008

Hence, angle between \vec{a} and $\vec{c} = \pi$.

15. The line passing through the points $(5, 1, a)$ and $(3, b, 1)$ crosses the yz -plane at the point $\left(0, \frac{17}{2}, \frac{-13}{2}\right)$. Then
- (1) $a = 2, b = 8$ (2) $a = 4, b = 6$
 (3) $a = 6, b = 4$ (4) $a = 8, b = 2$

Sol: (3)

Equation of line passing through $(5, 1, a)$ and $(3, b, 1)$ is

$$\frac{x-5}{2} = \frac{y-1}{1-b} = \frac{z-a}{a-1} = \lambda.$$

If line crosses yz -plane i.e., $x = 0$

$$x = 2\lambda + 5 = 0$$

$$\Rightarrow \lambda = -5/2,$$

$$\text{Since, } y = \lambda(1-b) + 1 = \frac{17}{2}$$

$$-\frac{5}{2}(1-b) + 1 = \frac{17}{2}$$

$$b = 4.$$

$$\text{Also, } z = \lambda(a-1) + a = -\frac{13}{2}$$

$$-\frac{5}{2}(a-1) + a = -\frac{13}{2}$$

$$\Rightarrow a = 6.$$

16. If the straight lines $\frac{x-1}{k} = \frac{y-2}{2} = \frac{z-3}{3}$ and $\frac{x-2}{3} = \frac{y-3}{k} = \frac{z-1}{2}$ intersect at a point, then the integer k is equal to
- (1) -5 (2) 5
 (3) 2 (4) -2

Sol: (1)

$$\frac{x-1}{k} = \frac{y-2}{2} = \frac{z-3}{3} \text{ and } \frac{x-2}{3} = \frac{y-3}{k} = \frac{z-1}{2}$$

Since lines intersect in a point

$$\begin{vmatrix} k & 2 & 3 \\ 3 & k & 2 \\ 1 & 1 & -2 \end{vmatrix} = 0$$

$$\therefore 2k^2 + 5k - 25 = 0$$

$$k = -5, 5/2.$$

Directions: Questions number 17 to 21 are Assertion–Reason type questions. Each of these questions contains two statements : Statement – 1 (Assertion) and Statement–2 (Reason). Each of these questions also has four alternative choices, only one of which is the correct answer. You have to select the correct choice.

17. Statement – 1: For every natural number $n \geq 2$, $\frac{1}{\sqrt{1}} + \frac{1}{\sqrt{2}} + \dots + \frac{1}{\sqrt{n}} > \sqrt{n}$.
- Statement –2: For every natural number $n \geq 2$, $\sqrt{n(n+1)} < n+1$.
- (1) Statement –1 is false, Statement –2 is true
 (2) Statement –1 is true, Statement –2 is true, Statement –2 is a correct explanation for Statement –1
 (3) Statement –1 is true, Statement –2 is true; Statement –2 is not a correct explanation for Statement –1.
 (4) Statement – 1 is true, Statement – 2 is false.

Sol: (3)

$$P(n) = \frac{1}{\sqrt{1}} + \frac{1}{\sqrt{2}} + \dots + \frac{1}{\sqrt{n}}$$

$$P(2) = \frac{1}{\sqrt{1}} + \frac{1}{\sqrt{2}} > \sqrt{2}$$

Let us assume that $P(k) = \frac{1}{\sqrt{1}} + \frac{1}{\sqrt{2}} + \dots + \frac{1}{\sqrt{k}} > \sqrt{k}$ is true

$\therefore P(k+1) = \frac{1}{\sqrt{1}} + \frac{1}{\sqrt{2}} + \dots + \frac{1}{\sqrt{k}} + \frac{1}{\sqrt{k+1}} > \sqrt{k+1}$ has to be true.

$$\text{L.H.S.} > \sqrt{k} + \frac{1}{\sqrt{k+1}} = \frac{\sqrt{k(k+1)} + 1}{\sqrt{k+1}}$$

Since $\sqrt{k(k+1)} > k \quad (\forall k \geq 0)$

$$\therefore \frac{\sqrt{k(k+1)} + 1}{\sqrt{k+1}} > \frac{k+1}{\sqrt{k+1}} = \sqrt{k+1}$$

Let $P(n) = \sqrt{n(n+1)} < n+1$

Statement -1 is correct.

$$P(2) = \sqrt{2 \times 3} < 3$$

If $P(k) = \sqrt{k(k+1)} < (k+1)$ is true

Now $P(k+1) = \sqrt{(k+1)(k+2)} < k+2$ has to be true

Since $(k+1) < k+2$

$$\therefore \sqrt{(k+1)(k+2)} < (k+2)$$

Hence Statement -2 is not a correct explanation of Statement -1.

18. Let A be a 2×2 matrix with real entries. Let I be the 2×2 identity matrix. Denote by $\text{tr}(A)$, the sum of diagonal entries of A . Assume that $A^2 = I$.

Statement -1: If $A \neq I$ and $A \neq -I$, then $\det A = -1$.

Statement -2: If $A \neq I$ and $A \neq -I$, then $\text{tr}(A) \neq 0$.

(1) Statement -1 is false, Statement -2 is true

(2) Statement -1 is true, Statement -2 is true, Statement -2 is a correct explanation for Statement -1

(3) Statement -1 is true, Statement -2 is true; Statement -2 is not a correct explanation for Statement -1.

(4) Statement -1 is true, Statement -2 is false.

Sol: (4)

$$\text{Let } A = \begin{bmatrix} a & b \\ c & d \end{bmatrix} \text{ so that } A^2 = \begin{bmatrix} a^2 + bc & ab + bd \\ ac + dc & bc + d^2 \end{bmatrix} = \begin{bmatrix} 1 & 0 \\ 0 & 1 \end{bmatrix}$$

$$\Rightarrow a^2 + bc = 1 = bc + d^2 \text{ and } (a+d)c = 0 = (a+d)b.$$

$$\text{Since } A \neq I, A \neq -I, a = -d \text{ and hence } \det A = \begin{vmatrix} \sqrt{1-bc} & b \\ c & -\sqrt{1-bc} \end{vmatrix} = -1 + bc - bc = -1$$

Statement 1 is true.

But $\text{tr. } A = 0$ and hence statement 2 is false.

19. Statement -1: $\sum_{r=0}^n (r+1)^n C_r = (n+2)2^{n-1}$.

$$\text{Statement -2: } \sum_{r=0}^n (r+1)^n C_r x^r = (1+x)^n + nx(1+x)^{n-1}.$$

(1) Statement -1 is false, Statement -2 is true

(2) Statement -1 is true, Statement -2 is true, Statement -2 is a correct explanation for Statement -1

(3) Statement -1 is true, Statement -2 is true; Statement -2 is not a correct explanation for Statement -1.

(4) Statement -1 is true, Statement -2 is false.

Sol: (2)

$$\begin{aligned}\sum_{r=0}^n (r+1)^n C_r &= \sum_{r=0}^n r^n C_r + {}^n C_r \\ &= \sum_{r=0}^n r \frac{n}{r} r^{n-1} C_{r-1} + \sum_{r=0}^n {}^n C_r = n 2^{n-1} + 2^n \\ &= 2^{n-1} (n+2)\end{aligned}$$

Statement -1 is true

$$\begin{aligned}\sum (r+1)^n C_r x^r &= \sum r^n C_r x^r + \sum {}^n C_r x^r \\ &= n \sum_{r=0}^n r^{n-1} C_{r-1} x^r + \sum_{r=0}^n {}^n C_r x^r = nx(1+x)^{n-1} + (1+x)^n\end{aligned}$$

Substituting $x = 1$

$$\sum (r+1)^n C_r = n 2^{n-1} + 2^n$$

Hence Statement -2 is also true and is a correct explanation of Statement -1.

20. Let p be the statement "x is an irrational number", q be the statement "y is a transcendental number", and r be the statement "x is a rational number iff y is a transcendental number".

Statement -1: r is equivalent to either q or p Statement -2: r is equivalent to $\sim(p \leftrightarrow \sim q)$.

(1) Statement -1 is false, Statement -2 is true

(2) Statement -1 is true, Statement -2 is true, Statement -2 is a correct explanation for Statement -1

(3) Statement -1 is true, Statement -2 is true; Statement -2 is not a correct explanation for Statement -1.

(4) Statement -1 is true, Statement -2 is false.

Sol: (4)Given statement $r = \sim p \leftrightarrow q$ Statement -1: $r_1 = (p \wedge \sim q) \vee (\sim p \wedge q)$ Statement -2: $r_2 = \sim(p \leftrightarrow \sim q) = (p \wedge q) \vee (\sim q \wedge \sim p)$ From the truth table of r , r_1 and r_2 , $r = r_1$.

Hence Statement -1 is true and Statement -2 is false.

21. In a shop there are five types of ice-creams available. A child buys six ice-creams.

Statement -1: The number of different ways the child can buy the six ice-creams is ${}^{10}C_5$.

Statement -2: The number of different ways the child can buy the six ice-creams is equal to the number of different ways of arranging 6 A's and 4 B's in a row.

(1) Statement -1 is false, Statement -2 is true

(2) Statement -1 is true, Statement -2 is true, Statement -2 is a correct explanation for Statement -1

(3) Statement -1 is true, Statement -2 is true; Statement -2 is not a correct explanation for Statement -1.

(4) Statement -1 is true, Statement -2 is false.

Sol: (1)

$$x_1 + x_2 + x_3 + x_4 + x_5 = 6$$

$${}^{5+6-1}C_{5-1} = {}^{10}C_4.$$

22. Let $f(x) = \begin{cases} (x-1)\sin\left(\frac{1}{x-1}\right), & \text{if } x \neq 1 \\ 0, & \text{if } x = 1 \end{cases}$. Then which one of the following is true?

(1) f is neither differentiable at $x = 0$ nor at $x = 1$ (2) f is differentiable at $x = 0$ and at $x = 1$ (3) f is differentiable at $x = 0$ but not at $x = 1$ (4) f is differentiable at $x = 1$ but not at $x = 0$ **Sol: (1)**

$$f'(1) = \lim_{h \rightarrow 0} \frac{f(1+h) - f(1)}{h}$$

$$\Rightarrow f'(1) = \lim_{h \rightarrow 0} \frac{(1+h-1)\sin\left(\frac{1}{1+h-1}\right) - 0}{h} = \lim_{h \rightarrow 0} \frac{h}{h} \sin\left(\frac{1}{h}\right)$$

$$\Rightarrow f'(1) = \lim_{h \rightarrow 0} \sin\left(\frac{1}{h}\right)$$

$\therefore f$ is not differentiable at $x = 1$.

$$\text{Similarly, } f'(0) = \lim_{h \rightarrow 0} \frac{f(h) - f(0)}{h}$$

$$\Rightarrow f'(0) = \lim_{h \rightarrow 0} \frac{(h-1)\sin\left(\frac{1}{h-1}\right) - \sin(1)}{h}$$

$\Rightarrow f$ is also not differentiable at $x = 0$.

23. The first two terms of a geometric progression add up to 12. The sum of the third and the fourth terms is 48. If the terms of the geometric progression are alternately positive and negative, then the first term is

- (1) -4 (2) -12
(3) 12 (4) 4

Sol:

(2)

Let a, ar, ar^2, \dots

$$a + ar = 12 \quad \dots(1)$$

$$ar^2 + ar^3 = 48 \quad \dots(2)$$

dividing (2) by (1), we have

$$\frac{ar^2(1+r)}{a(r+1)} = 4$$

$$\Rightarrow r^2 = 4 \text{ if } r \neq -1$$

$$\therefore r = -2$$

also, $a = -12$ (using (1)).

24. Suppose the cube $x^3 - px + q$ has three distinct real roots where $p > 0$ and $q > 0$. Then which one of the following holds?

(1) The cubic has minima at $\sqrt{\frac{p}{3}}$ and maxima at $-\sqrt{\frac{p}{3}}$

(2) The cubic has minima at $-\sqrt{\frac{p}{3}}$ and maxima at $\sqrt{\frac{p}{3}}$

(3) The cubic has minima at both $\sqrt{\frac{p}{3}}$ and $-\sqrt{\frac{p}{3}}$

(4) The cubic has maxima at both $\sqrt{\frac{p}{3}}$ and $-\sqrt{\frac{p}{3}}$

Sol:

(1)

Let $f(x) = x^3 - px + q$

Now for maxima/minima

$$f'(x) = 0$$

$$\Rightarrow 3x^2 - p = 0$$

$$\Rightarrow x^2 = \frac{p}{3}$$

$$\therefore x = \pm \sqrt{\frac{p}{3}}$$

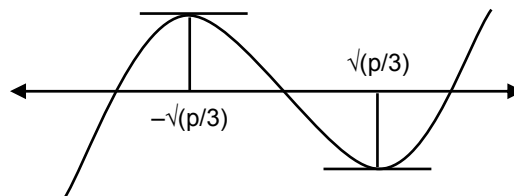

25. How many real solutions does the equation $x^7 + 14x^5 + 16x^3 + 30x - 560 = 0$ have?

- (1) 7 (2) 1
(3) 3 (4) 5

Solutions to AIEEE - 2008

Sol: (2)

$$x^7 + 14x^5 + 16x^3 + 30x - 560 = 0$$

$$\text{Let } f(x) = x^7 + 14x^5 + 16x^3 + 30x$$

$$\Rightarrow f'(x) = 7x^6 + 70x^4 + 48x^2 + 30 > 0 \forall x.$$

$\therefore f(x)$ is an increasing function $\forall x$.

26. The statement $p \rightarrow (q \rightarrow p)$ is equivalent to

(1) $p \rightarrow (p \rightarrow q)$

(2) $p \rightarrow (p \vee q)$

(3) $p \rightarrow (p \wedge q)$

(4) $p \rightarrow (p \leftrightarrow q)$

Sol: (2)

$$p \rightarrow (q \rightarrow p) = \sim p \vee (q \rightarrow p)$$

$$= \sim p \vee (\sim q \vee p) \quad \text{since } p \vee \sim p \text{ is always true}$$

$$= \sim p \vee p \vee q = p \rightarrow (p \vee q).$$

27. The value of $\cot\left(\operatorname{cosec}^{-1}\frac{5}{3} + \tan^{-1}\frac{2}{3}\right)$ is

(1) $\frac{6}{17}$

(2) $\frac{3}{17}$

(3) $\frac{4}{17}$

(4) $\frac{5}{17}$

Sol: (1)

$$\text{Let } E = \cot\left(\operatorname{cosec}^{-1}\frac{5}{3} + \tan^{-1}\frac{2}{3}\right)$$

$$\Rightarrow E = \cot\left(\tan^{-1}\left(\frac{3}{4}\right) + \tan^{-1}\left(\frac{2}{3}\right)\right)$$

$$\Rightarrow E = \cot\left(\tan^{-1}\left(\frac{\frac{3}{4} + \frac{2}{3}}{1 - \frac{3}{4} \cdot \frac{2}{3}}\right)\right)$$

$$\Rightarrow E = \cot\left(\tan^{-1}\frac{17}{6}\right) = \frac{6}{17}.$$

28. The differential equation of the family of circles with fixed radius 5 units and centre on the line $y = 2$ is

(1) $(x - 2)y'^2 = 25 - (y - 2)^2$

(2) $(y - 2)y'^2 = 25 - (y - 2)^2$

(3) $(y - 2)^2 y'^2 = 25 - (y - 2)^2$

(4) $(x - 2)^2 y'^2 = 25 - (y - 2)^2$

Sol: (3)

$$(x - h)^2 + (y - 2)^2 = 25 \quad \dots(1)$$

$$\Rightarrow 2(x - h) + 2(y - 2) \frac{dy}{dx} = 0$$

$$\Rightarrow (x - h) = -(y - 2) \frac{dy}{dx}$$

substituting in (1), we have

$$(y - 2)^2 \left(\frac{dy}{dx}\right)^2 + (y - 2)^2 = 25$$

$$(y - 2)^2 y'^2 = 25 - (y - 2)^2.$$

29. Let $I = \int_0^1 \frac{\sin x}{\sqrt{x}} dx$ and $J = \int_0^1 \frac{\cos x}{\sqrt{x}} dx$. Then which one of the following is true?

(1) $I > \frac{2}{3}$ and $J > 2$

(2) $I < \frac{2}{3}$ and $J < 2$

(3) $I < \frac{2}{3}$ and $J > 2$

(4) $I > \frac{2}{3}$ and $J < 2$

Solutions to AIEEE - 2008

Sol: (2)

$$I = \int_0^1 \frac{\sin x}{\sqrt{x}} dx < \int_0^1 \frac{x}{\sqrt{x}} dx = \int_0^1 \sqrt{x} dx = \frac{2}{3} x^{3/2} \Big|_0^1 = \frac{2}{3}$$

$$\Rightarrow I < \frac{2}{3}$$

$$J = \int_0^1 \frac{\cos x}{\sqrt{x}} dx < \int_0^1 \frac{1}{\sqrt{x}} dx = 2\sqrt{x} \Big|_0^1 = 2$$

$$\therefore J \leq 2.$$

30. The area of the plane region bounded by the curves $x + 2y^2 = 0$ and $x + 3y^2 = 1$ is equal to

(1) $\frac{5}{3}$

(2) $\frac{1}{3}$

(3) $\frac{2}{3}$

(4) $\frac{4}{3}$

Sol: (4)

Solving the equations we get the points of intersection $(-2, 1)$ and $(-2, -1)$. The bounded region is shown as shaded region.

$$\text{The required area} = 2 \int_0^1 (1 - 3y^2) - (-2y^2)$$

$$= 2 \int_0^1 (1 - y^2) dy = 2 \left[y - \frac{y^3}{3} \right]_0^1 = 2 \times \frac{2}{3} = \frac{4}{3}.$$

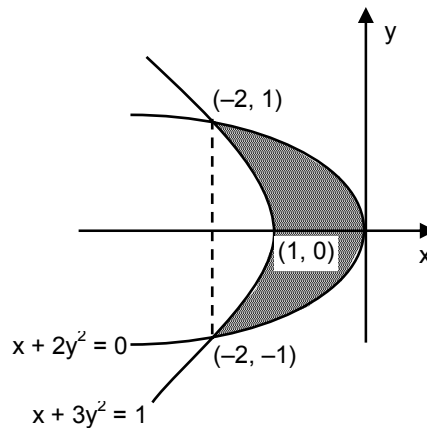
31. The value of $\sqrt{2} \int \frac{\sin x dx}{\sin\left(x - \frac{\pi}{4}\right)}$ is

(1) $x + \log \left| \cos \left(x - \frac{\pi}{4} \right) \right| + c$

(2) $x - \log \left| \sin \left(x - \frac{\pi}{4} \right) \right| + c$

(3) $x + \log \left| \sin \left(x - \frac{\pi}{4} \right) \right| + c$

(4) $x - \log \left| \cos \left(x - \frac{\pi}{4} \right) \right| + c$

Sol: (3)

$$\sqrt{2} \int \frac{\sin x dx}{\sin\left(x - \frac{\pi}{4}\right)} = \sqrt{2} \int \frac{\sin\left(x - \frac{\pi}{4} + \frac{\pi}{4}\right) dx}{\sin\left(x - \frac{\pi}{4}\right)}$$

$$= \sqrt{2} \int \left(\cos \frac{\pi}{4} + \cot\left(x - \frac{\pi}{4}\right) \sin \frac{\pi}{4} \right) dx$$

$$= \int dx + \int \cot\left(x - \frac{\pi}{4}\right) dx$$

$$= x + \ln \left| \sin \left(x - \frac{\pi}{4} \right) \right| + c.$$

32. How many different words can be formed by jumbling the letters in the word MISSISSIPPI in which no two S are adjacent?

(1) $8 \cdot {}^6C_4 \cdot {}^7C_4$

(2) $6 \cdot 7 \cdot {}^8C_4$

(3) $6 \cdot 8 \cdot {}^7C_4$

(4) $7 \cdot {}^6C_4 \cdot {}^8C_4$

Sol: (4)

Other than S, seven letters M, I, I, I, P, P, I can be arranged in $\frac{7!}{2!4!} = 7 \cdot 5 \cdot 3$.

Now four S can be placed in 8 spaces in 8C_4 ways.
Desired number of ways = $7 \cdot 5 \cdot 3 \cdot {}^8C_4 = 7 \cdot {}^6C_4 \cdot {}^8C_4$.

33. Let a, b, c be any real numbers. Suppose that there are real numbers x, y, z not all zero such that $x = cy + bz$, $y = az + cx$ and $z = bx + ay$. Then $a^2 + b^2 + c^2 + 2abc$ is equal to
- (1) 2 (2) -1
(3) 0 (4) 1

Sol: (4)

The system of equations $x - cy - bz = 0$, $cx - y + az = 0$ and $bx + ay - z = 0$ have non-trivial solution if

$$\begin{vmatrix} 1 & -c & -b \\ c & -1 & a \\ b & a & -1 \end{vmatrix} = 0 \Rightarrow 1(1 - a^2) + c(-c - ab) - b(ca + b) = 0$$

$$\Rightarrow a^2 + b^2 + c^2 + 2abc = 1.$$

34. Let A be a square matrix all of whose entries are integers. Then which one of the following is true?
- (1) If $\det A = \pm 1$, then A^{-1} exists but all its entries are not necessarily integers
(2) If $\det A \neq \pm 1$, then A^{-1} exists and all its entries are non-integers
(3) If $\det A = \pm 1$, then A^{-1} exists and all its entries are integers
(4) If $\det A = \pm 1$, then A^{-1} need not exist

Sol: (3)

Each entry of A is integer, so the cofactor of every entry is an integer and hence each entry in the adjoint of matrix A is integer.

$$\text{Now } \det A = \pm 1 \text{ and } A^{-1} = \frac{1}{\det(A)} (\text{adj } A)$$

\Rightarrow all entries in A^{-1} are integers.

35. The quadratic equations $x^2 - 6x + a = 0$ and $x^2 - cx + 6 = 0$ have one root in common. The other roots of the first and second equations are integers in the ratio 4 : 3. Then the common root is
- (1) 1 (2) 4
(3) 3 (4) 2

Sol: (4)

Let α and 4β be roots of $x^2 - 6x + a = 0$ and α , 3β be the roots of $x^2 - cx + 6 = 0$, then

$$\alpha + 4\beta = 6 \text{ and } 4\alpha\beta = a$$

$$\alpha + 3\beta = c \text{ and } 3\alpha\beta = 6.$$

$$\text{We get } \alpha\beta = 2 \Rightarrow a = 8$$

$$\text{So the first equation is } x^2 - 6x + 8 = 0 \Rightarrow x = 2, 4$$

$$\text{If } \alpha = 2 \text{ and } 4\beta = 4 \text{ then } 3\beta = 3$$

$$\text{If } \alpha = 4 \text{ and } 4\beta = 2, \text{ then } 3\beta = 3/2 \text{ (non-integer)}$$

$$\therefore \text{ common root is } x = 2.$$

Chemistry

PART - B

36. The organic chloro compound, which shows complete stereochemical inversion during a S_N2 reaction, is
- (1) $(C_2H_5)_2CHCl$ (2) $(CH_3)_3CCl$
(3) $(CH_3)_2CHCl$ (4) CH_3Cl

Sol. (4)

For S_N2 reaction, the C atom is least hindered towards the attack of nucleophile in the case of (CH_3Cl) .

Hence, (4) is the correct answer.

Solutions to AIEEE - 2008

39. Identify the wrong statements in the following:
- (1) Chlorofluorocarbons are responsible for ozone layer depletion
 - (2) Greenhouse effect is responsible for global warming
 - (3) Ozone layer does not permit infrared radiation from the sun to reach the earth
 - (4) Acid rains is mostly because of oxides of nitrogen and sulphur

Sol. (3)
Ozone layer does not allow ultraviolet radiation from sun to reach earth.

40. Phenol, when it first reacts with concentrated sulphuric acid and then with concentrated nitric acid, gives
- (1) 2,4,6-trinitrobenzene
 - (2) o-nitrophenol
 - (3) p-nitrophenol
 - (4) nitrobenzene

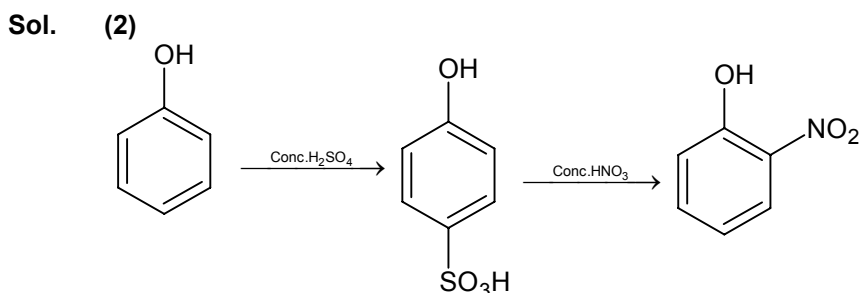

41. In the following sequence of reactions, the alkene affords the compound 'B'
- $$\text{CH}_3\text{CH}=\text{CHCH}_3 \xrightarrow{\text{O}_3} \text{A} \xrightarrow[\text{Zn}]{\text{H}_2\text{O}} \text{B}$$
- The compound B is
- (1) $\text{CH}_3\text{CH}_2\text{CHO}$
 - (2) CH_3COCH_3
 - (3) $\text{CH}_3\text{CH}_2\text{COCH}_3$
 - (4) CH_3CHO

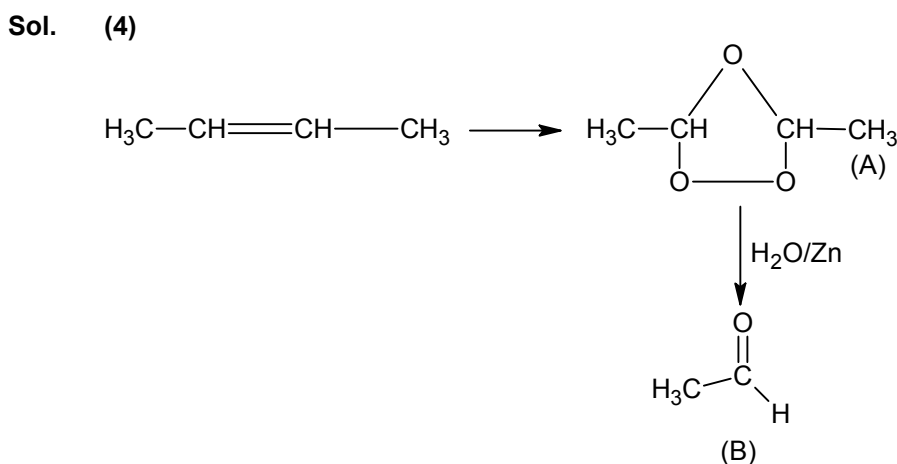

42. Larger number of oxidation states are exhibited by the actinoids than those by the lanthanoids, the main reason being
- (1) 4f orbitals more diffused than the 5f orbitals
 - (2) lesser energy difference between 5f and 6d than between 4f and 5d orbitals
 - (3) more energy difference between 5f and 6d than between 4f and 5d orbitals
 - (4) more reactive nature of the actinoids than the lanthanoids

Sol. (2)
Being lesser energy difference between 5f and 6d than 4f and 5d orbitals.

43. In which of the following octahedral complexes of Co (at. no. 27), will the magnitude of Δ_o be the highest?
- (1) $[\text{Co}(\text{CN})_6]^{3-}$
 - (2) $[\text{Co}(\text{C}_2\text{O}_4)_3]^{3-}$
 - (3) $[\text{Co}(\text{H}_2\text{O})_6]^{3+}$
 - (4) $[\text{Co}(\text{NH}_3)_6]^{3+}$

Solutions to AIEEE - 2008

Sol. (1)

CN^\ominus is stronger ligand hence Δ_o is highest.

44. At 80°C , the vapour pressure of pure liquid 'A' is 520 mm Hg and that of pure liquid 'B' is 1000 mm Hg. If a mixture solution of 'A' and 'B' boils at 80°C and 1 atm pressure, the amount of 'A' in the mixture is (1 atm = 760 mm Hg)

- (1) 52 mol percent (2) 34 mol percent
(3) 48 mol percent (4) 50 mol percent

Sol. (4)

$$P_T = P_A^\circ X_A + P_B^\circ X_B$$

$$760 = 520X_A + P_B^\circ (1 - X_A)$$

$$\Rightarrow X_A = 0.5$$

Thus, mole% of A = 50%

45. For a reaction $\frac{1}{2}A \rightarrow 2B$, rate of disappearance of 'A' is related to the rate of appearance of 'B' by the expression

$$(1) -\frac{d[A]}{dt} = \frac{1}{2} \frac{d[B]}{dt}$$

$$(2) -\frac{d[A]}{dt} = \frac{1}{4} \frac{d[B]}{dt}$$

$$(3) -\frac{d[A]}{dt} = \frac{d[B]}{dt}$$

$$(4) -\frac{d[A]}{dt} = 4 \frac{d[B]}{dt}$$

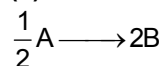
Sol. (2)

$$\frac{-2d[A]}{dt} = + \frac{d[B]}{2dt}$$

$$\frac{-d[A]}{dt} = \frac{1}{4} \frac{d[B]}{dt}$$

46. The equilibrium constants K_{P_1} and K_{P_2} for the reactions $X \rightleftharpoons 2Y$ and $Z \rightleftharpoons P + Q$, respectively are in the ratio of 1 : 9. If the degree of dissociation of X and Z be equal then the ratio of total pressure at these equilibria is

- (1) 1 : 36 (2) 1 : 1
(3) 1 : 3 (4) 1 : 9

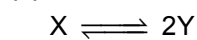
Sol. (1)

$$\begin{array}{ccc} 1 & & 0 \\ (1-x) & & 2x \end{array}$$

$$K_{P_1} = \frac{(2x)^2}{(1-x)} \left(\frac{P_1}{1+x} \right)^{-1}$$

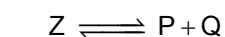

$$\begin{array}{ccc} 1 & & 0 & 0 \\ (1-x) & & x & x \end{array}$$

$$K_{P_2} = \frac{x^2}{(1-x)} \left(\frac{P_2}{1+x} \right)^{-1}$$

$$\frac{4 \times P_1}{P_2} = \frac{1}{9} \Rightarrow \frac{P_1}{P_2} = \frac{1}{36}$$

47. Oxidising power of chlorine in aqueous solution can be determined by the parameters indicated below:

Solutions to AIEEE - 2008

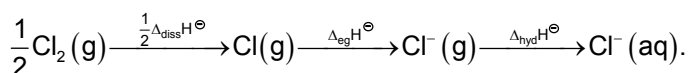

The energy involved in the conversion of $\frac{1}{2}\text{Cl}_2(\text{g})$ to $\text{Cl}^-(\text{g})$

(using the data,

$$\Delta_{\text{diss}}H^\ominus_{\text{Cl}_2} = 240 \text{ kJmol}^{-1}, \Delta_{\text{eg}}H^\ominus_{\text{Cl}} = -349 \text{ kJmol}^{-1}, \Delta_{\text{hyd}}H^\ominus_{\text{Cl}} = -381 \text{ kJmol}^{-1})$$

will be

- (1) $+152 \text{ kJmol}^{-1}$ (2) -610 kJmol^{-1}
 (3) -850 kJmol^{-1} (4) $+120 \text{ kJmol}^{-1}$

Sol. (2)

For the process $\frac{1}{2}\text{Cl}_2(\text{g}) \longrightarrow \text{Cl}^-_{\text{aq}}$

$$\begin{aligned} \Delta H &= \frac{1}{2}\Delta H_{\text{diss}} \text{ of } \text{Cl}_2 + \Delta_{\text{eg}}\text{Cl} + \Delta_{\text{hyd}}\text{Cl}^- \\ &= +\frac{240}{2} - 349 - 381 \\ &= -610 \text{ kJ mol}^{-1} \end{aligned}$$

48. Which of the following factors is of **no significance** for roasting sulphide ores to the oxides and not subjecting the sulphide ores to carbon reduction directly?

- (1) Metal sulphides are thermodynamically more stable than CS_2
 (2) CO_2 is thermodynamically more stable than CS_2
 (3) Metal sulphides are less stable than the corresponding oxides
 (4) CO_2 is more volatile than CS_2

Sol. (1)

49. Bakelite is obtained from phenol by reacting with

- (1) $(\text{CH}_2\text{OH})_2$ (2) CH_3CHO
 (3) CH_3COCH_3 (4) HCHO

Sol. (4)

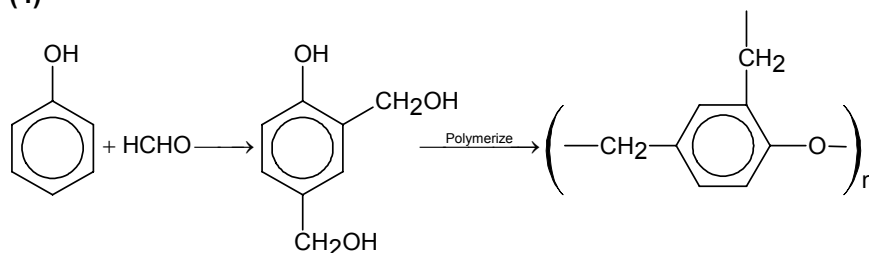

50. For the following three reactions a, b and c, equilibrium constants are given:

- a. $\text{CO}(\text{g}) + \text{H}_2\text{O}(\text{g}) \rightleftharpoons \text{CO}_2(\text{g}) + \text{H}_2(\text{g}); K_1$
 b. $\text{CH}_4(\text{g}) + \text{H}_2\text{O}(\text{g}) \rightleftharpoons \text{CO}(\text{g}) + 3\text{H}_2(\text{g}); K_2$
 c. $\text{CH}_4(\text{g}) + 2\text{H}_2\text{O}(\text{g}) \rightleftharpoons \text{CO}_2(\text{g}) + 4\text{H}_2(\text{g}); K_3$

Which of the following relations is correct?

- (1) $K_1\sqrt{K_2} = K_3$ (2) $K_2K_3 = K_1$
 (3) $K_3 = K_1K_2$ (4) $K_3 \cdot K_2^3 = K_1^2$

Sol. (3)

Equation (c) = equation (a) + equation (b)

Thus $K_3 = K_1 \cdot K_2$

51. The absolute configuration of

Solutions to AIEEE - 2008

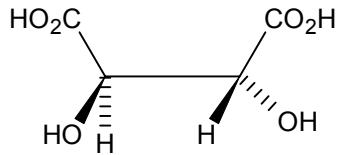

is

- (1) S, S
(3) R, S

- (2) R, R
(4) S, R

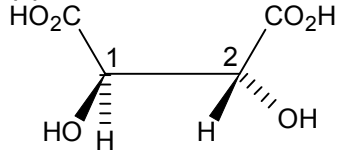
Sol.**(2)**Both C₁ and C₂ have R – configuration.

52. The electrophile, E⁺ attacks the benzene ring to generate the intermediate σ-complex. Of the following, which σ-complex is of lowest energy?

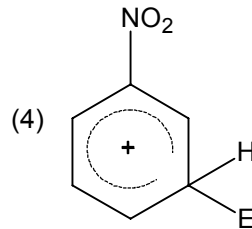
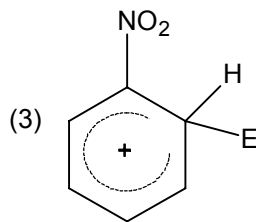
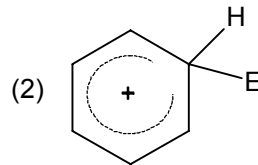
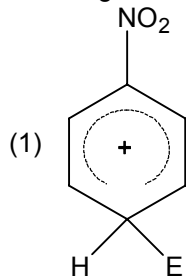
**Sol.****(2)**—NO₂ is electron withdrawing which will destabilize σ - complex.

53. α-D-(+)-glucose and β-D-(+)-glucose are

- (1) conformers
(3) anomers

- (2) epimers
(4) enantiomers

Sol.**(3)**

α - D (+) glucose and β - D (+) glucose are anomers.

54. Standard entropy of X₂, Y₂ and XY₃ are 60, 40 and 50 JK⁻¹mol⁻¹, respectively. For the reaction,

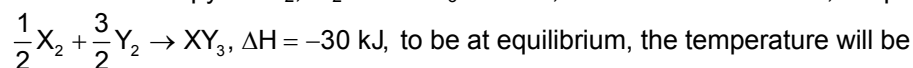

- (1) 1250 K
(3) 750 K

- (2) 500 K
(4) 1000 K

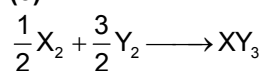
Sol.**(3)**

$$\Delta S_{\text{reaction}} = 50 - \left(\frac{3}{2} \times 40 + \frac{1}{2} \times 60 \right) = -40 \text{ Jmol}^{-1}$$

$$\Delta G = \Delta H - T\Delta S$$

$$\text{at equilibrium } \Delta G = 0$$

Solutions to AIEEE - 2008

$$\Delta H = T\Delta S$$

$$30 \times 10^3 = T \times 40$$

$$\Rightarrow T = 750 \text{ K}$$

55. Four species are listed below

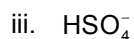
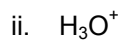
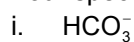

Which one of the following is the correct sequence of their acid strength?

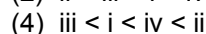
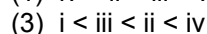
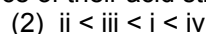
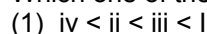

Sol. (3)

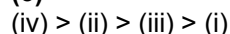

56. Which one of the following constitutes a group of the isoelectronic species?

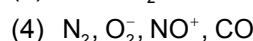
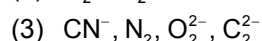
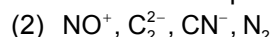
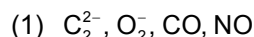

Sol. (2)

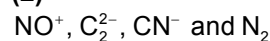

all have fourteen electrons.

57. Which one of the following pairs of species have the same bond order?

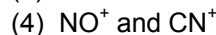
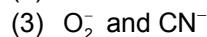
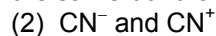
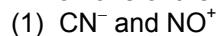

Sol. (1)

Both are isoelectronic and have same bond order.

58. The ionization enthalpy of hydrogen atom is $1.312 \times 10^6 \text{ Jmol}^{-1}$. The energy required to excite the electron in the atom from $n = 1$ to $n = 2$ is

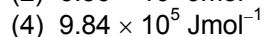
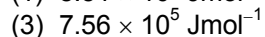
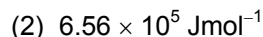
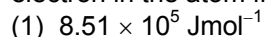

Sol. (4)

$$\Delta E = E_2 - E_1 = -\frac{1.312 \times 10^6}{2^2} - \left(-\frac{1.312 \times 10^6}{1} \right)$$

$$= 9.84 \times 10^5 \text{ J mol}^{-1}$$

59. Which one of the following is the correct statement?

(1) Boric acid is a protonic acid

(2) Beryllium exhibits coordination number of six

(3) Chlorides of both beryllium and aluminium have bridged chloride structures in solid phase

(4) $\text{B}_2\text{H}_6 \cdot 2\text{NH}_3$ is known as 'inorganic benzene'

Sol. (3)

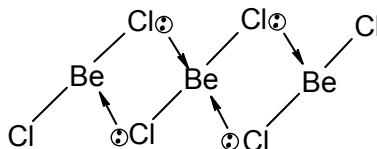
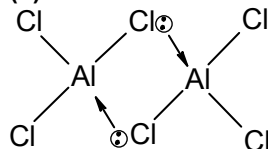

60. Given $E_{\text{Cr}^{3+}/\text{Cr}}^\circ = -0.72 \text{ V}$, $E_{\text{Fe}^{2+}/\text{Fe}}^\circ = -0.42 \text{ V}$. The potential for the cell

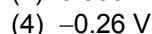
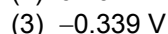
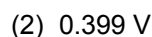
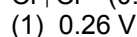

Sol. (1)

As $E_{\text{Cr}/\text{Cr}^{3+}}^0 = -0.72 \text{ V}$ and $E_{\text{Fe}^{2+}/\text{Fe}}^0 = -0.42 \text{ V}$

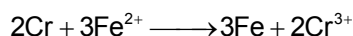

$$E_{\text{cell}} = E_{\text{cell}}^0 - \frac{0.0591}{6} \log \frac{(\text{Cr}^{3+})^2}{(\text{Fe}^{2+})^3}$$

$$= (-0.42 + 0.72) - \frac{0.0591}{6} \log \frac{(0.1)^2}{(0.01)^3} = 0.30 - \frac{0.0591}{6} \log \frac{(0.1)^2}{(0.01)^3}$$

$$= 0.30 - \frac{0.0591}{6} \log \frac{10^{-2}}{10^{-6}} = 0.30 - \frac{0.0591}{6} \log 10^4$$

$$E_{\text{cell}} = 0.2606 \text{ V}$$

61. Amount of oxalic acid present in a solution can be determined by its titration with KMnO_4 solution in the presence of H_2SO_4 . The titration gives unsatisfactory result when carried out in the presence of HCl , because HCl

- (1) gets oxidised by oxalic acid to chlorine
- (2) furnishes H^+ ions in addition to those from oxalic acid
- (3) reduces permanganate to Mn^{2+}
- (4) oxidises oxalic acid to carbon dioxide and water

Sol. (3)

HCl being stronger reducing agent reduces MnO_4^- to Mn^{2+} and result of the titration becomes unsatisfactory.

62. The vapour pressure of water at 20°C is 17.5 mm Hg. If 18 g of glucose ($\text{C}_6\text{H}_{12}\text{O}_6$) is added to 178.2 g of water at 20°C , the vapour pressure of the resulting solution will be

- (1) 17.675 mm Hg
- (2) 15.750 mm Hg
- (3) 16.500 mm Hg
- (4) 17.325 mm Hg

Sol. (4)

$$\frac{P^0 - P_s}{P_s} = X_{\text{solute}}$$

$$\frac{17.5 - P_s}{P_s} = \frac{0.1}{10}$$

$$\frac{17.5 - P_s}{P_s} = 0.01$$

$$\Rightarrow P_s = 17.325 \text{ mm Hg}$$

63. Among the following substituted silanes the one which will give rise to cross linked silicone polymer on hydrolysis is

- (1) R_4Si
- (2) RSiCl_3
- (3) R_2SiCl_2
- (4) R_3SiCl

Sol. (2)

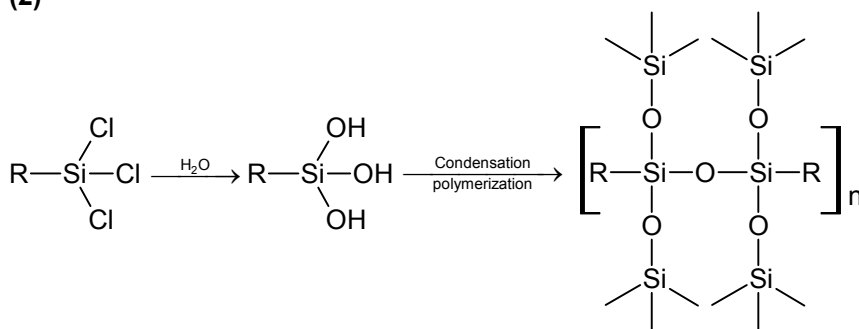

64. In context with the industrial preparation of hydrogen from water gas ($\text{CO} + \text{H}_2$), which of the following is the correct statement?

Solutions to AIEEE - 2008

- (1) CO and H₂ are fractionally separated using differences in their densities
- (2) CO is removed by absorption in aqueous Cu₂Cl₂ solution
- (3) H₂ is removed through occlusion with Pd
- (4) CO is oxidised to CO₂ with steam in the presence of a catalyst followed by absorption of CO₂ in alkali

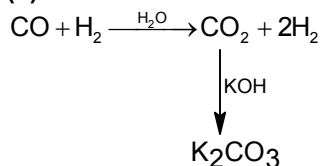
Sol. (4)

65. In a compound atoms of element Y form ccp lattice and those of element X occupy 2/3rd of tetrahedral voids. The formula of the compound will be

- (1) X₄Y₃
- (2) X₂Y₃
- (3) X₂Y
- (4) X₃Y₄

Sol. (1)

No. of atoms of Y = 4

$$\text{No. of atoms of X} = \frac{2}{3} \times 8$$

Formula of compound will be X₄Y₃

66. Gold numbers of protective colloids A, B, C and D are 0.50, 0.01, 0.10 and 0.005, respectively. The correct order of their protective powers is

- (1) D < A < C < B
- (2) C < B < D < A
- (3) A < C < B < D
- (4) B < D < A < C

Sol. (3)

Higher the gold number lesser will be the protective power of colloid.

67. The hydrocarbon which can react with sodium in liquid ammonia is

- (1) CH₃CH₂CH₂C≡CCH₂CH₂CH₃
- (2) CH₃CH₂C≡CH
- (3) CH₃CH=CHCH₃
- (4) CH₃CH₂C≡CCH₂CH₃

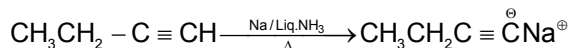
Sol. (2)

It is a terminal alkyne, having acidic hydrogen.

Note: Solve it as a case of terminal alkynes, otherwise all alkynes react with Na in liq. NH₃.

68. The treatment of CH₃MgX with CH₃C≡C-H produces

- (1) CH₃-CH=CH₂
- (2) CH₃C≡C-CH₃
- (3) $\begin{array}{c} \text{H} \quad \text{H} \\ | \quad | \\ \text{CH}_3 - \text{C} = \text{C} - \text{CH}_3 \end{array}$
- (4) CH₄

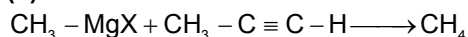
Sol. (4)

69. The correct decreasing order of priority for the functional groups of organic compounds in the IUPAC system of nomenclature is

- (1) -COOH, -SO₃H, -CONH₂, -CHO
- (2) -SO₃H, -COOH, -CONH₂, -CHO
- (3) -CHO, -COOH, -SO₃H, -CONH₂
- (4) -CONH₂, -CHO, -SO₃H, -COOH

Sol. (2)-SO₃H, -COOH, -CONH₂, -CHO

70. The pK_a of a weak acid, HA, is 4.80. The pK_b of a weak base, BOH, is 4.78. The pH of an aqueous solution of the corresponding salt, BA, will be

- (1) 9.58
(3) 7.01

- (2) 4.79
(4) 9.22

Sol. (3)

It is a salt of weak acid and weak base

$$[H^+] = \sqrt{\frac{K_w \times K_a}{K_b}}$$

$$pH = 7.01$$

Physics

PART – C

Directions: Questions No. 71, 72 and 73 are based on the following paragraph.

Wave property of electrons implies that they will show diffraction effects. Davisson and Germer demonstrated this by diffracting electrons from crystals. The law governing the diffraction from a crystal is obtained by requiring that electron waves reflected from the planes of atoms in a crystal interfere constructively (see in figure).

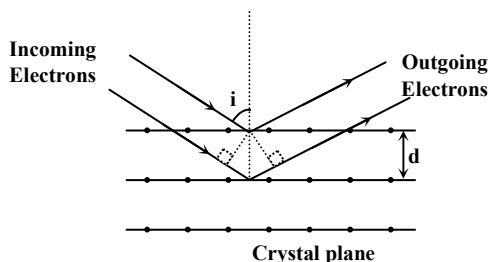

71. Electrons accelerated by potential V are diffracted from a crystal. If $d = 1 \text{ \AA}$ and $i = 30^\circ$, V should be about ($h = 6.6 \times 10^{-34} \text{ Js}$, $m_e = 9.1 \times 10^{-31} \text{ kg}$, $e = 1.6 \times 10^{-19} \text{ C}$)
- (1) 2000 V (2) 50 V
(3) 500 V (4) 1000 V

Sol. (2)

$$2d \cos i = n\lambda$$

$$2d \cos i = \frac{h}{\sqrt{2meV}}$$

$$v = 50 \text{ volt}$$

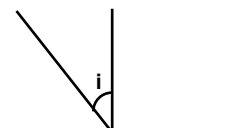

72. If a strong diffraction peak is observed when electrons are incident at an angle ' i ' from the normal to the crystal planes with distance ' d ' between them (see figure), de Broglie wavelength λ_{dB} of electrons can be calculated by the relationship (n is an integer)
- (1) $d \sin i = n\lambda_{dB}$ (2) $2d \cos i = n\lambda_{dB}$
(3) $2d \sin i = n\lambda_{dB}$ (4) $d \cos i = n\lambda_{dB}$

Sol. (4)

$$2d \cos i = n\lambda_{dB}$$

73. In an experiment, electrons are made to pass through a narrow slit of width ' d ' comparable to their de Broglie wavelength. They are detected on a screen at a distance ' D ' from the slit (see figure).

Solutions to AIEEE - 2008

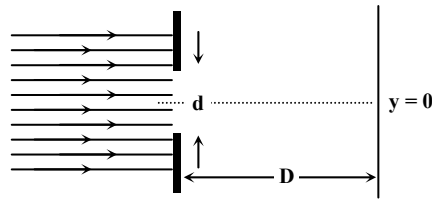

Which of the following graph can be expected to represent the number of electrons 'N' detected as a function of the detector position 'y' (y = 0 corresponds to the middle of the slit)?

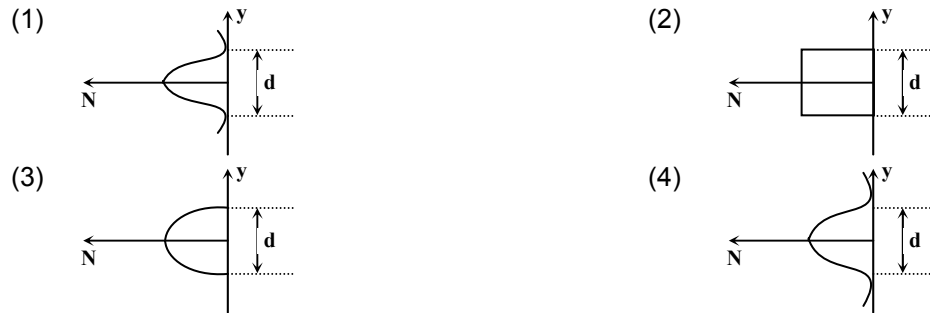

Sol. (4)
Diffraction pattern will be wider than the slit.

74. A planet in a distant solar system is 10 times more massive than the earth and its radius is 10 times smaller. Given that the escape velocity from the earth is 11 kms^{-1} , the escape velocity from the surface of the planet would be

- (1) 1.1 kms^{-1} (2) 11 kms^{-1}
(3) 110 kms^{-1} (4) 0.11 kms^{-1}

Sol. (3)
$$v_{\text{esc}} = \sqrt{\frac{2GM}{R}} = \sqrt{\frac{2G \times 10M}{R/10}} = 10 \times 11 = 110 \text{ km/s}$$

75. A spherical solid ball of volume V is made of a material of density ρ_1 . It is falling through a liquid of density ρ_2 ($\rho_2 < \rho_1$). Assume that the liquid applies a viscous force on the ball that is proportional to the square of its speed v , i.e., $F_{\text{viscous}} = -kv^2$ ($k > 0$). The terminal speed of the ball is

- (1) $\sqrt{\frac{Vg(\rho_1 - \rho_2)}{k}}$ (2) $\frac{Vg\rho_1}{k}$
(3) $\sqrt{\frac{Vg\rho_1}{k}}$ (4) $\frac{Vg(\rho_1 - \rho_2)}{k}$

Sol. (1)
$$\rho_1 Vg - \rho_2 Vg = kv_T^2$$

$$\Rightarrow v_T = \sqrt{\frac{Vg(\rho_1 - \rho_2)}{k}}$$

76. Shown in the figure below is a meter-bridge set up with null deflection in the galvanometer.

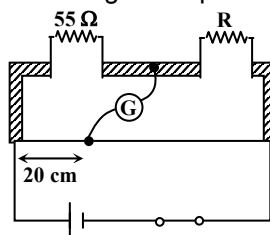

The value of the unknown resistor R is

- (1) 13.75Ω (2) 220Ω
(3) 110Ω (4) 55Ω

Sol. (2)

$$\frac{55}{20} = \frac{R}{80} \Rightarrow R = \frac{55 \times 8}{2} = 220 \Omega$$

77. A thin rod of length 'L' is lying along the x-axis with its ends at $x = 0$ and $x = L$. Its linear density (mass/length) varies with x as $k\left(\frac{x}{L}\right)^n$, where n can be zero or any positive number. If the position x_{CM} of the centre of mass of the rod is plotted against 'n', which of the following graphs best approximates the dependence of x_{CM} on n ?

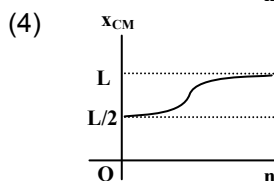
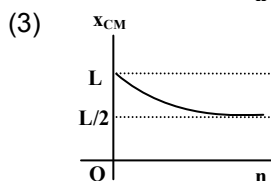
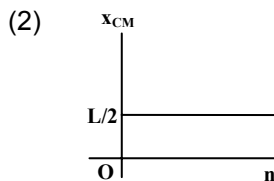
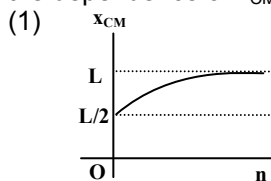
**Sol. (1)**

$$x_{cm} = \frac{\int dm x}{\int dm} = \frac{\int \lambda dx \cdot x}{\int \lambda dx} = \frac{\int k \left(\frac{x}{L}\right)^n \cdot x dx}{\int k \left(\frac{x}{L}\right)^n dx} = \frac{\left[\frac{kx^{n+2}}{(n+2)L^n} \right]_0^L}{\left[\frac{kx^{n+1}}{(n+1)L^n} \right]_0^L} = \left[\frac{x(n+1)}{n+2} \right]_0^L$$

$$x_{cm} = \frac{L}{2}, \frac{2L}{3}, \frac{3L}{4}, \frac{4L}{5}, \frac{5L}{6}, \dots$$

78. While measuring the speed of sound by performing a resonance column experiment, a student gets the first resonance condition at a column length of 18 cm during winter. Repeating the same experiment during summer, she measures the column length to be x cm for the second resonance. Then

- (1) $18 > x$
 (3) $54 > x > 36$

- (2) $x > 54$
 (4) $36 > x > 18$

Sol. (2)

$$n = \frac{1}{4x} \sqrt{\frac{\gamma RT}{M}}$$

$$xn = \frac{1}{4} \sqrt{\frac{\gamma RT}{M}}$$

$$x \propto \sqrt{T}$$

79. The dimension of magnetic field in M, L, T and C (Coulomb) is given as

- (1) $MLT^{-1}C^{-1}$ (2) MT^2C^{-2}
 (3) $MT^{-1}C^{-1}$ (4) $MT^{-2}C^{-1}$

Sol. (3)

$$F = qvB$$

$$B = F/qv = MC^{-1}T^{-1}$$

80. Consider a uniform square plate of side 'a' and mass 'm'. The moment of inertia of this plate about an axis perpendicular to its plane and passing through one of its corners is

- (1) $\frac{5}{6} ma^2$ (2) $\frac{1}{12} ma^2$
 (3) $\frac{7}{12} ma^2$ (4) $\frac{2}{3} ma^2$

Solutions to AIEEE - 2008

Sol. (4)

$$I = I_{cm} + m \left(\frac{a\sqrt{2}}{2} \right)^2 = \frac{ma^2}{6} + \frac{ma^2}{2} = \frac{2}{3}ma^2$$

81. A body of mass $m = 3.513 \text{ kg}$ is moving along the x -axis with a speed of 5.00 ms^{-1} . The magnitude of its momentum is recorded as

- (1) 17.6 kg ms^{-1} (2) $17.565 \text{ kg ms}^{-1}$
 (3) 17.56 kg ms^{-1} (4) 17.57 kg ms^{-1}

Sol. (1)

$$P = mv = 3.513 \times 5.00 \approx 17.6$$

82. An athlete in the olympic games covers a distance of 100 m in 10 s . His kinetic energy can be estimated to be in the range

- (1) $200 \text{ J} - 500 \text{ J}$ (2) $2 \times 10^5 \text{ J} - 3 \times 10^5 \text{ J}$
 (3) $20,000 \text{ J} - 50,000 \text{ J}$ (4) $2,000 \text{ J} - 5,000 \text{ J}$

Sol. (4)

Approximate mass = 60 kg

Approximate velocity = 10 m/s

$$\text{Approximate KE} = \frac{1}{2} \times 60 \times 100 = 3000 \text{ J}$$

KE range \Rightarrow 2000 to 5000 joule

83. A parallel plate capacitor with air between the plates has a capacitance of 9 pF . The separation between its plates is ' d '. The space between the plates is now filled with two dielectrics. One of the dielectrics has dielectric constant $k_1 = 3$ and thickness $\frac{d}{3}$ while the other one has dielectric constant

$k_2 = 6$ and thickness $\frac{2d}{3}$. Capacitance of the capacitor is now

- (1) 1.8 pF (2) 45 pF
 (3) 40.5 pF (4) 20.25 pF

Sol. (3)

$$C' = \frac{A\epsilon_0}{\frac{d_1}{3} + \frac{d_2}{6}} = \frac{A\epsilon_0}{\frac{d}{9} + \frac{2d}{18}} = \frac{18A\epsilon_0}{4d}$$

$$C' = 40.5 \text{ PF}$$

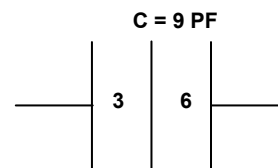

84. The speed of sound in oxygen (O_2) at a certain temperature is 460 ms^{-1} . The speed of sound in helium (He) at the same temperature will be (assumed both gases to be ideal)

- (1) 460 ms^{-1} (2) 500 ms^{-1}
 (3) 650 ms^{-1} (4) 330 ms^{-1}

Sol. No option is correct

$$v = \sqrt{\frac{\gamma RT}{M}}$$

$$\frac{V_1}{V_2} = \sqrt{\frac{\gamma_1 M_2}{\gamma_2 M_1}} = \sqrt{\frac{\frac{7}{5} \times 4}{\frac{5}{3} \times 32}}$$

$$\frac{460}{V_2} = \sqrt{\frac{21}{25 \times 8}} \Rightarrow V_2 = \frac{460 \times 5 \times 2\sqrt{2}}{\sqrt{21}} = 1420$$

Solutions to AIEEE - 2008

Directions: Question No. 89 and 90 are based on the following paragraph.

Consider a block of conducting material of resistivity ' ρ ' shown in the figure. Current ' I ' enters at 'A' and leaves from 'D'. We apply superposition principle to find voltage ' ΔV ' developed between 'B' and 'C'. The calculation is done in the following steps:

- (i) Take current ' I ' entering from 'A' and assume it to spread over a hemispherical surface in the block.
- (ii) Calculate field $E(r)$ at distance ' r ' from A by using Ohm's law $E = \rho j$, where j is the current per unit area at ' r '.
- (iii) From the ' r ' dependence of $E(r)$, obtain the potential $V(r)$ at r .
- (iv) Repeat (i), (ii) and (iii) for current ' I ' leaving 'D' and superpose results for 'A' and 'D'.

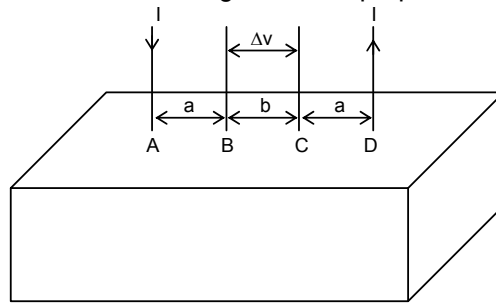

89. ΔV measured between B and C is

- | | |
|---|--|
| <p>(1) $\frac{\rho I}{\pi a} - \frac{\rho I}{\pi(a+b)}$</p> <p>(3) $\frac{\rho I}{2\pi a} - \frac{\rho I}{2\pi(a+b)}$</p> | <p>(2) $\frac{\rho I}{a} - \frac{\rho I}{(a+b)}$</p> <p>(4) $\frac{\rho I}{2\pi(a-b)}$</p> |
|---|--|

Sol. (3)
Choosing A as origin,

$$E = \rho j = \rho \frac{I}{2\pi r^2}$$

$$V_C - V_B = -\frac{\rho I}{2\pi} \int_a^{(a+b)} \frac{1}{r^2} dr = \frac{\rho I}{2\pi} \left[\frac{1}{(a+b)} - \frac{1}{a} \right]$$

$$V_B - V_C = \frac{\rho I}{2\pi} \left[\frac{1}{a} - \frac{1}{(a+b)} \right]$$

90. For current entering at A, the electric field at a distance ' r ' from A is

- | | |
|---|--|
| <p>(1) $\frac{\rho I}{8\pi r^2}$</p> <p>(3) $\frac{\rho I}{2\pi r^2}$</p> | <p>(2) $\frac{\rho I}{r^2}$</p> <p>(4) $\frac{\rho I}{4\pi r^2}$</p> |
|---|--|

Sol. (3)

91. A student measures the focal length of convex lens by putting an object pin at a distance ' u ' from the lens and measuring the distance ' v ' of the image pin. The graph between ' u ' and ' v ' plotted by the student should look like

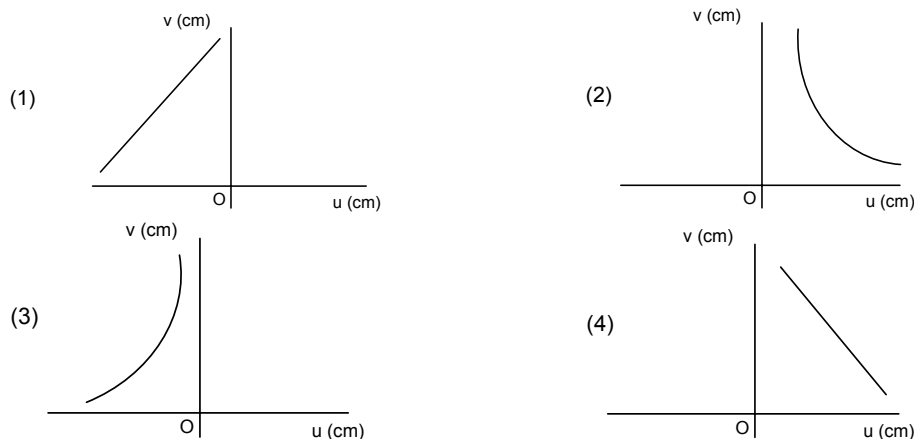

Sol. (3)

$$\frac{1}{v} - \frac{1}{u} = \frac{1}{f} = \text{constant}$$

92. A block of mass 0.50 kg is moving with a speed of 2.00 m/s on a smooth surface. It strikes another mass of 1.00 kg and then they move together as a single body. The energy loss during the collision is
- (1) 0.16 J (2) 1.00 J
(3) 0.67 J (4) 0.34 J

Sol. (3)

$$m_1 u_1 + m_2 u_2 = (m_1 + m_2)v$$

$$v = 2/3 \text{ m/s}$$

$$\text{Energy loss} = \frac{1}{2}(0.5) \times (2)^2 - \frac{1}{2}(1.5) \times \left(\frac{2}{3}\right)^2 = 0.67 \text{ J}$$

93. A capillary tube (A) is dropped in water. Another identical tube (B) is dipped in a soap water solution. Which of the following shows the relative nature of the liquid columns in the two tubes?

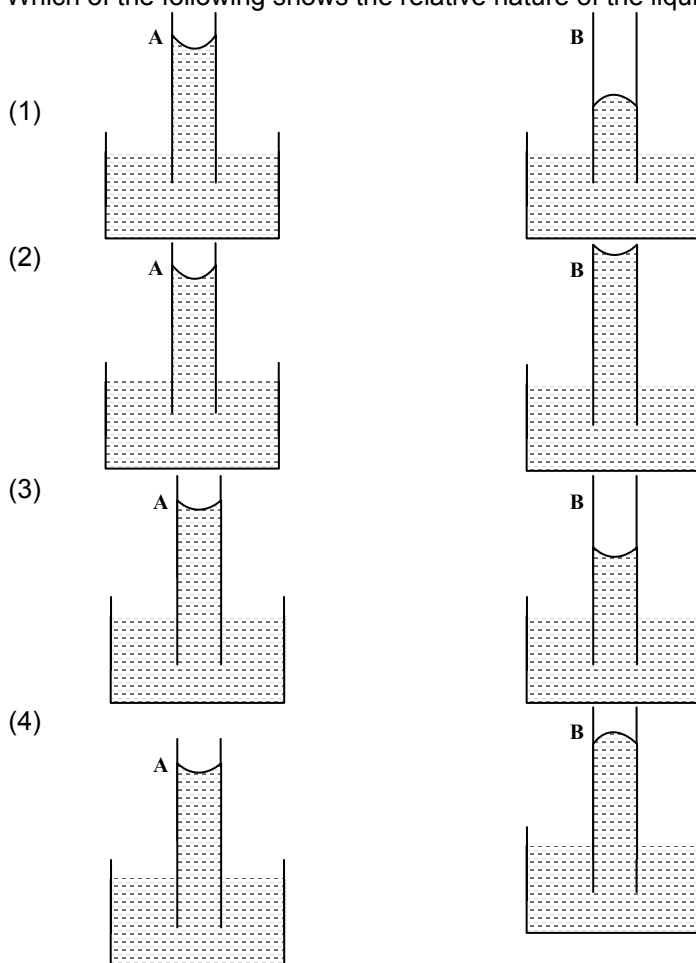

Sol. (3)

$$\text{Capillary rise } h = \frac{2T \cos \theta}{\rho g r}. \text{ As soap solution has lower } T, h \text{ will be low.}$$

94. Suppose an electron is attracted towards the origin by a force k/r where 'k' is a constant and 'r' is the distance of the electron from the origin. By applying Bohr model to this system, the radius of the n^{th} orbital of the electron is found to be ' r_n ' and the kinetic energy of the electron to be T_n . Then which of the following is true?
- (1) $T_n \propto 1/n^2$, $r_n \propto n^2$ (2) T_n independent of n , $r_n \propto n$
(3) $T_n \propto 1/n$, $r_n \propto n$ (4) $T_n \propto 1/n$, $r_n \propto n^2$

Sol. (2)

$$\frac{k}{r} = \frac{mv^2}{r}$$

$$mv^2 = k$$

(independent of r)

$$n\left(\frac{h}{2\pi}\right) = mvr \Rightarrow r \propto n \text{ and } T = \frac{1}{v}mv^2 \text{ is independent of } n.$$

95. A wave travelling along the x-axis is described by the equation $y(x, t) = 0.005 \cos(\alpha x - \beta t)$. If the wavelength and the time period of the wave are 0.08 m and 2.0 s, respectively, then α and β in appropriate units are

(1) $\alpha = 25.00 \pi, \beta = \pi$

(2) $\alpha = \frac{0.08}{\pi}, \frac{2.0}{\pi}$

(3) $\alpha = \frac{0.04}{\pi}, \beta = \frac{1.0}{\pi}$

(4) $\alpha = 12.50 \pi, \beta = \frac{\pi}{2.0}$

Sol. (1)

$$y = 0.005 \cos(\alpha x - \beta t)$$

comparing the equation with the standard form,

$$y = A \cos\left[\left(\frac{x}{\lambda} - \frac{t}{T}\right)2\pi\right]$$

$$2\pi/\lambda = \alpha \text{ and } 2\pi/T = \beta$$

$$\alpha = 2\pi/0.08 = 25.00 \pi$$

$$\beta = \pi$$

96. Two coaxial solenoids are made by winding thin insulated wire over a pipe of cross sectional area $A = 10 \text{ cm}^2$ and length = 20 cm. If one of the solenoids has 300 turns and the other 400 turns, their mutual inductance is ($\mu_0 = 4\pi \times 10^{-7} \text{ Tm A}^{-1}$)

(1) $2.4 \pi \times 10^{-5} \text{ H}$

(2) $4.8 \pi \times 10^{-4} \text{ H}$

(3) $4.8 \pi \times 10^{-5} \text{ H}$

(4) $2.4 \pi \times 10^{-4} \text{ H}$

Sol. (4)

$$M = \frac{\mu_0 N_1 N_2 A}{\ell} = 2.4 \pi \times 10^{-4} \text{ H}$$

97. In the circuit below, A and B represent two inputs and C represents the output.

The circuit represents

(1) NOR gate

(2) AND gate

(3) NAND gate

(4) OR gate

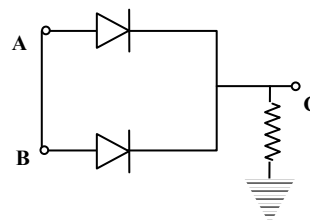
**Sol. (4)**

A	B	C
0	0	0
0	1	1
1	0	1
1	1	1

98. A body is at rest at $x = 0$. At $t = 0$, it starts moving in the positive x-direction with a constant acceleration. At the same instant another body passes through $x = 0$ moving in the positive x-direction with a constant speed. The position of the first body is given by $x_1(t)$ after time 't' and that of the second body by $x_2(t)$ after the same time interval. Which of the following graphs correctly describes $(x_1 - x_2)$ as a function of time 't'?

Solutions to AIEEE - 2008

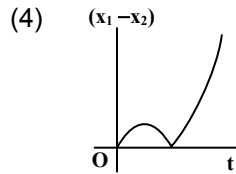
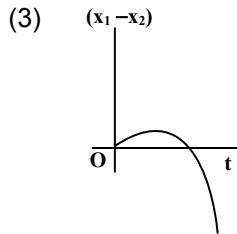
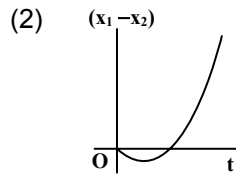
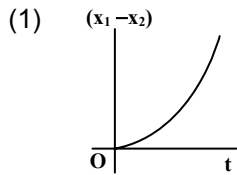

Sol. (2)

$$x_1(t) = \frac{1}{2}at^2$$

$$x_2(t) = vt$$

$$x_1 - x_2 = \frac{1}{2}at^2 - vt$$

99. An experiment is performed to find the refractive index of glass using a travelling microscope. In this experiment distance are measured by

- (1) a vernier scale provided on the microscope (2) a standard laboratory scale
 (3) a meter scale provided on the microscope (4) a screw gauge provided on the microscope

Sol. (1)

100. A thin spherical shell of radius R has charge Q spread uniformly over its surface. Which of the following graphs most closely represents the electric field $E(r)$ produced by the shell in the range $0 \leq r < \infty$, where r is the distance from the centre of the shell?

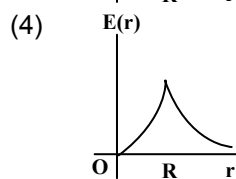
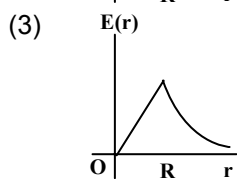
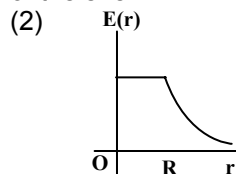
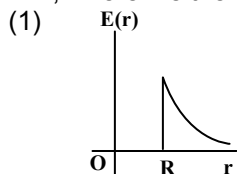

Sol. (1)

$$E(r) = \begin{cases} 0 & \text{if } r < R \\ \frac{Q}{4\pi\epsilon_0 r^2} & \text{if } r \geq R \end{cases}$$

101. A 5V battery with internal resistance 2Ω and a 2V battery with internal resistance 1Ω are connected to a 10Ω resistor as shown in the figure. The current in the 10Ω resistor is

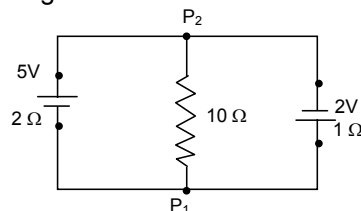

- (1) 0.27 A P_2 to P_1
 (3) 0.03 A P_2 to P_1

- (2) 0.03 A P_1 to P_2
 (4) 0.27 A P_1 to P_2

Sol. (3)

$$V_{P_2} - V_{P_1} = \frac{\frac{5}{2} + \frac{0}{10} - \frac{2}{1}}{\frac{1}{2} + \frac{1}{10} + \frac{1}{1}}$$

$$I = \frac{V_{P_2} - V_{P_1}}{10} = 0.03 \text{ from } P_2 \rightarrow P_1$$

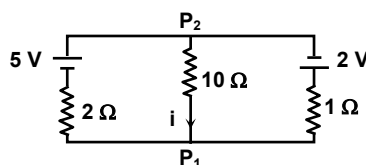

102. A horizontal overhead power line is at a height of 4m from the ground and carries a current of 100 A from east to west. The magnetic field directly below it on the ground is ($\mu_0 = 4\pi \times 10^{-7} \text{ T m A}^{-1}$)

- (1) $2.5 \times 10^{-7} \text{ T}$ southward (2) $5 \times 10^{-6} \text{ T}$ northward
 (3) $5 \times 10^{-6} \text{ T}$ southward (4) $2.5 \times 10^{-7} \text{ T}$ northward

Sol. (3)

$$B = \frac{\mu_0 i}{2\pi R} = \frac{4\pi \times 10^{-7} \times 100}{2\pi \times 4} = 5 \times 10^{-6} \text{ T southward}$$

103. Relative permittivity and permeability of a material are ϵ_r and μ_r , respectively. Which of the following values of these quantities are allowed for a diamagnetic material?

- (1) $\epsilon_r = 0.5, \mu_r = 1.5$ (2) $\epsilon_r = 1.5, \mu_r = 0.5$
 (3) $\epsilon_r = 0.5, \mu_r = 0.5$ (4) $\epsilon_r = 1.5, \mu_r = 1.5$

Sol. (2)

104. Two full turns of the circular scale of a screw gauge cover a distance of 1 mm on its main scale. The total number of divisions on the circular scale is 50. Further, it is found that the screw gauge has a zero error of -0.03 mm while measuring the diameter of a thin wire, a student notes the main scale reading of 3 mm and the number of circular scale divisions in line with the main scale as 35. The diameter of the wire is

- (1) 3.32 mm (2) 3.73 mm
 (3) 3.67 mm (4) 3.38 mm

Sol. (4)

$$\text{Diameter} = \text{M.S.R.} + \text{C.S.R} \times \text{L.C.} + \text{Z.E.} = 3 + 35 \times (0.5/50) + 0.03 = 3.38 \text{ mm}$$

105. An insulated container of gas has two chambers separated by an insulating partition. One of the chambers has volume V_1 and contains ideal gas at pressure P_1 and temperature T_1 . The other chamber has volume V_2 and contains ideal gas at pressure P_2 and temperature T_2 . If the partition is removed without doing any work on the gas, the final equilibrium temperature of the gas in the container will be

- (1) $\frac{T_1 T_2 (P_1 V_1 + P_2 V_2)}{P_1 V_1 T_2 + P_2 V_2 T_1}$ (2) $\frac{P_1 V_1 T_1 + P_2 V_2 T_2}{P_1 V_1 + P_2 V_2}$
 (3) $\frac{P_1 V_1 T_2 + P_2 V_2 T_1}{P_1 V_1 + P_2 V_2}$ (4) $\frac{T_1 T_2 (P_1 V_1 + P_2 V_2)}{P_1 V_1 T_1 + P_2 V_2 T_2}$

Sol. (1)

$$U = U_1 + U_2$$

$$T = \frac{(P_1 V_1 + P_2 V_2) T_1 T_2}{(P_1 V_1 T_2 + P_2 V_2 T_1)}$$

Solutions to AIEEE - 2008**AIEEE-2008, PAPER(C-5)****ANSWERS**

1.	(2)	2.	(2)	3.	(3)	4.	(1)
5.	(2)	6.	(3)	7.	(4)	8.	(3)
9.	(4)	10.	(4)	11.	(4)	12.	(4)
13.	(4)	14.	(4)	15.	(3)	16.	(1)
17.	(3)	18.	(4)	19.	(2)	20.	(4)
21.	(1)	22.	(1)	23.	(2)	24.	(1)
25.	(2)	26.	(2)	27.	(1)	28.	(3)
29.	(2)	30.	(4)	31.	(3)	32.	(4)
33.	(4)	34.	(3)	35.	(4)	36.	(4)
37.	(1)	38.	(4)	39.	(3)	40.	(2)
41.	(4)	42.	(2)	43.	(1)	44.	(4)
45.	(2)	46.	(1)	47.	(2)	48.	(1)
49.	(4)	50.	(3)	51.	(2)	52.	(2)
53.	(3)	54.	(3)	55.	(3)	56.	(2)
57.	(1)	58.	(4)	59.	(3)	60.	(1)
61.	(3)	62.	(4)	63.	(2)	64.	(4)
65.	(1)	66.	(3)	67.	(2)	68.	(4)
69.	(2)	70.	(3)	71.	(2)	72.	(4)
73.	(4)	74.	(3)	75.	(1)	76.	(2)
77.	(1)	78.	(2)	79.	(3)	80.	(4)
81.	(1)	82.	(4)	83.	(3)	84.	no option is correct
85.	(4)	86.	(2)	87.	(4)	88.	(2)
89.	(3)	90.	(3)	91.	(3)	92.	(3)
93.	(3)	94.	(2)	95.	(1)	96.	(4)
97.	(4)	98.	(2)	99.	(1)	100.	(1)
101.	(3)	102.	(3)	103.	(2)	104.	(4)
105.	(1)						