

ELECTRICAL ENGINEERING

PAPER - I

Time Allowed: Three Hours

Maximum Marks: 200

Candidates should attempt SIX questions, selecting TWO questions from Part A, ONE from Part ONE from Part C and TWO from Part D.

PART A

1. (a) Prove that the load impedance which absorbs the maximum power from a source is the conjugate of the impedance of the source.

A loudspeaker is connected across terminals A and B of the network shown in Fig. 1. What should its impedance be to obtain maximum power dissipation in it?

8

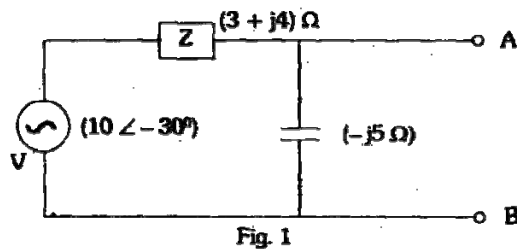

- (b) Find the current $i(t)$ in a series R-L-C circuit composing resistor $R = 4\Omega$, inductor $L = 1$ henry and capacitor $C = \frac{1}{3}$ Farad when each of the following driving force voltage is applied:

(i) ramp voltage $9t(t-2)$ (ii) step voltage $4u(t-3)$ (iii) impulse voltage $2\delta(t-1)$

9

- (c) In the given circuit of Fig. 2, switch K is moved from position 1 position 2 at time $t = 0$. At time $t = 0^-$, the current through inductor 'L' is I_0 and the voltage across capacitor 'C' is V_0 in the polarity shown. At time $t = 0^+$, current source $i_1(t)$ and resistor R_2 get connected to the $R_1 - L - C$ parallel circuit. Find the voltage $V(s)$ and $V(t)$ across the $R_1 - L - C$ parallel circuit.

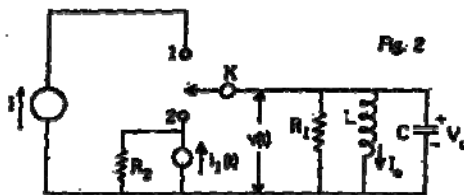

9

- (d) Find the initial and final values of the following function, using initial value and final value theorem respectively;

$$\frac{(s-1)}{(s+1)(s+2)}$$

6

2. (a) The given network of Fig. 3 is driven by a current source and is terminated by resistor R_2 at port 2. For this terminated 2-port network, calculate (1) transfer functions $G_{21}(s)$, $\alpha_{21}(s)$, $Z_{21}(s)$ and $Y_{21}(s)$ and (2) driving point impedance $Z_{11}(s)$.

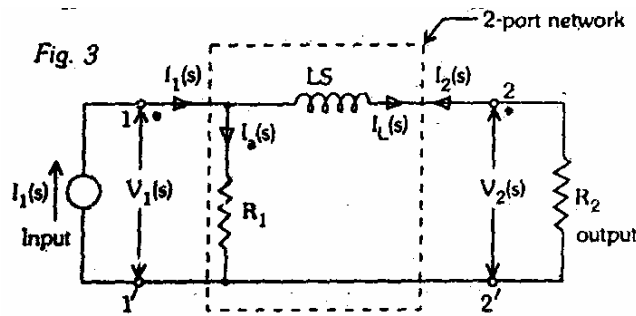

10

- (b) Show that the $[Z]$ and $[A]$ matrices of the symmetrical lattice network illustrated in Fig. 4 are respectively:

$$\begin{bmatrix} (Z_1 + Z_2)/2 & (Z_2 - Z_1)/2 \\ (Z_2 + Z_1)/2 & (Z_1 - Z_2)/2 \end{bmatrix}$$

and

$$\begin{bmatrix} (Z_1 + Z_2)/(Z_2 - Z_1) & 2Z_1Z_2/(Z_2 - Z_1) \\ 2/(Z_2 - Z_1) & (Z_1 + Z_2)/(Z_2 - Z_1) \end{bmatrix}$$

10

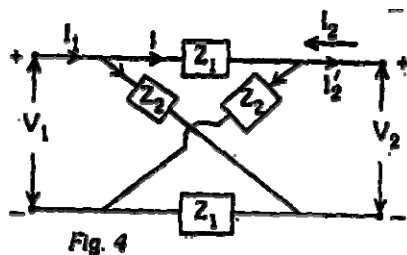

- (c) (i) Explain how the time domain response of a system can be determined from s-plane plot of poles and zeros of its network function and from the transform of the network sources.
 (ii) For the network shown in Fig. 5, find the driving point impedance $Z(s)$, Locate the poles and zeros of this function.

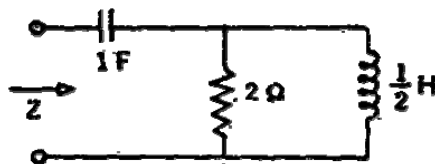

Fig. 5

12

3. (a) What do you understand by Positive Real Function? Give its properties. Show that the function

$$F(s) = \frac{s^2 + a_1s + a_0}{s^2 + b_1s + b_0}$$

with coefficients a_1 , a_0 , b_1 and b_0 as real positive constants, is positive real if

$$a_1 b_1 \gg (\sqrt{a_0} - \sqrt{b_0})^2$$

Hence check the positive realness of the function

$$Z(s) = \frac{s^2 + s + 6}{s^2 + s + 1}$$

12

- (b) Point out the difference in the philosophy between Foster and Cauer form of synthesis of a given driving point impedance.

Find the second Cauer form of LC network for the impedance function

$$Z(s) = \frac{s^4 + 10s^2 + 9}{s^3 + 4s}$$

10

- (c) Give the basic properties of signal flow graphs. Find the Transfer function $\frac{C(s)}{R(s)}$ for a system whose signal flow graph is shown in Fig. 6.

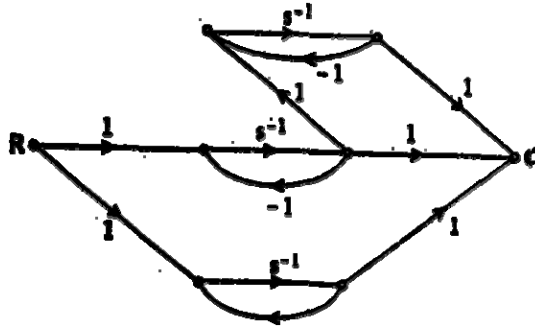

Fig. 6.

10

PART B

4. (a) Define magnetic vector potential.

12

Derive an expression for the mutual inductance between two straight parallel wires of length L, using magnetic vector potential.

- (b) (i) A straight wire of length L is charged with electricity of amount q per unit length. This is placed near an earthed conducting sphere of radius r. The centre of the sphere is at a perpendicular distance 's' from the wire. The ends of the wire are equidistant from the centre of the sphere. Find the charge on the sphere. Assume that the distribution of charge on the wire is unaffected by induction.

8

- (ii) What is the skin depth of current penetration in copper at frequency of 10^4 MHz. if the resistivity is 1.7×10^{-6} ohm-cm.

4

- (c) Show with usual notations, that

$$\nabla \times H = \bar{J}_c + \frac{\partial \bar{D}}{\partial t}$$

Find $\nabla \times \bar{H}$ if the field is varying harmonically.

12

5. (a) Derive the Helmholtz equation for \bar{E} in the form

$$\nabla^2 \bar{E} - \mu\sigma \frac{\partial \bar{E}}{\partial t} - \mu\epsilon \frac{\partial^2 \bar{E}}{\partial t^2} = 0$$

The electric field intensity associated with a plane wave travelling in a perfect dielectric medium is given by

$$E_x(z, t) = 12 \cos(2\pi \times 10^7 t - 0.1 \pi x) \text{ V/m}$$

Find:

- (i) Velocity of propagation
- (ii) Intrinsic impedance

12

- (b) Explain what you understand by Perpendicular polarization and Parallel polarization.

Given two dielectric mediums, medium 1 is free space and medium 2 has $\epsilon_2 = 4\epsilon_0$ and $\mu = \mu_0$. Determine reflection coefficient for oblique incidence $\theta_1 = 30^\circ$ for

- (i) Perpendicular polarization
- (ii) Parallel polarization

12

- (c) Derive from the Maxwell's equations, the Poynting theorem, and explain the physical significance of the terms involved.

12

PART B

6. (a) Briefly explain different mechanisms of polarization. A material has N elements/ m^3 of polarizability α .

The total electric field acting on each element is $E + E_i$, when E is the applied field and E_i is the additional field caused by the presence of the polarized dipoles. The simplest calculation for E gives the value $P/3\epsilon_0$. Prove that

$$N\alpha = \frac{\epsilon_r - 1}{\epsilon_r + 2} \text{ where } \epsilon_r \text{ is the relative permittivity.}$$

12

- (b) What are the properties of good insulating materials for use in Electrical Devices? How are these properties affected by moisture?

Give the classification of solid insulating materials.

12

- (c) Briefly explain the following theories of breakdown of liquid dielectrics:

- (i) Colloidal theory (ii) Bubble theory (iii) Electronic theory

- 12
7. (a) Explain what you understand by Anti-ferromagnetism and Ferri-magnetism. Show the variation of susceptibility with temperature for the materials pertaining to these phenomena. What are Ferrites ? Give their characteristics and applications. 12
- (b) What are the properties that high conducting materials should possess ? What are the materials used for (i) electrical contacts, (ii) rheostats, and (iii) fuses ? Give reasons. 12
- (c) (i) Explain Hall effect in semi-conductors: What is Hall angle?
(ii) Find the diffusion coefficients of holes and electrons for germanium at 300 K. The carrier mobilities in $\text{cm}^2/\text{volt-sec}$ at 300 K for electrons and holes are respectively 3600 and 1700. Density of carriers is $2.5 \times 10^{13}/\text{cm}^2$. Boltzmann's constant, $K = 1.38 \times 10^{23} \text{ J degree}^{-1}$
 $e = 1.602 \times 10^{-19} \text{ C}$. 12

PART D

8. (a) What is Wagner Earth ? Explain its use in conjunction with a bridge network. Draw relevant circuit diagram. 10
- (b) Explain, with the help of a schematic diagram, the working of a storage type of cathode ray oscilloscope. 10
- (c) Fig. 7 shows the bridge arrangement for measuring a small capacitance C_x , C_1 and C_2 are equal high quality variable air capacitors. C_3 is a fixed high quality capacitance of much smaller value than the maximum value of C_3 (about 1/10 of C_2). The following two balances are obtained :
- (i) with switch 'S' open, and with C_2 at its maximum value, C_1 is adjusted for balance.
(ii) with switch 'S' closed, and C_1 left unaltered, C_2 is adjusted to C_2' to give a new balance.

Prove that

$$C_x = C_3^2 (C_2 - C_2') / (C_2 C_2' + C_3^2 - C_2 C_3)$$

If $R = 1000\Omega$, $C_2 = C_1 = 1000 \mu\text{F}$ and $C_3 = 50\mu\text{F}$,

and assuming variable capacitors are readable to $\pm 5\mu\text{F}$, with what accuracy could a capacitance $1 \mu\text{F}$ be measured?

Fig. 7

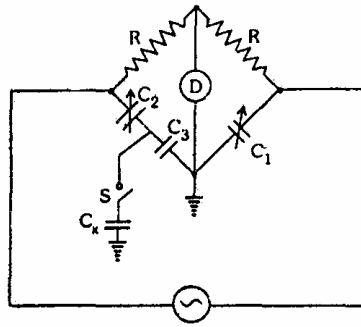

12

9. (a) What are 'Resolvers'? How are they classified? Give their applications. Give the winding configuration and principle of action of an electromagnetic resolver.

10

- (b) Discuss the advantages of electric voltmeter. Explain an electronic voltmeter using bridge circuit for full-wave rectification.

A saw tooth voltage has a peak value of 160 V and a time period of 3.6 seconds as shown in Fig. 8. Calculate the error when measuring this voltage with an average reading voltmeter calibrated in terms of rms value of a sinusoidal wave.

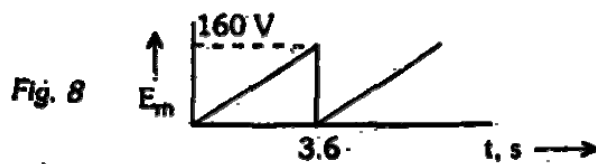

12

- (c) Draw a functional block diagram and explain the principle of working of a digital frequency meter.

10

10. (a) What are the different methods of data transmission? Explain with the help of block diagram a general telemetry system.

What do you understand by 'Time Division multiplexing' and Frequency Division multiplexing? Why are these done?

10

- (b) What are optical displacement transducers? Discuss the two types of principles of operation of these transducers. What are Encoders? Why are they used?

10

- (c) Describe the basic components of magnetic tape recorder for, instrumentation using direct recording techniques. Explain FM method of tape recording and give its advantages and disadvantages.

10

ELECTRICAL ENGINEERING

PAPER - II

Time Allowed: Three Hours

Maximum Marks: 200

Candidates should attempt FIVE questions in all, choosing at least ONE from each section.

PART A

1. (a) Explain how multitasking facilities are made available in a digital computer. 10
- (b) Write a FUNCTION SUBPROGRAM to compute the Euclidean norm of a given real matrix A of order r x s where the is given, by
- $$\text{Euclidean norm} = \left(\sum_i \sum_j a_{ij}^2 \right)^{0.5}$$
- 10
- (c) Distinguish between ROM, PROM and EPROM. 10
- (d) Given the coordinates of two points X(x₁, x₂, x₃) and Y(y₁, y₂, y₃) write a SUBROUTINE SUBPROGRAM to compute the distance between these points and the direction cosines of the vector XY. 10
2. (a) Briefly explain the tents algorithms and 'arithmetic assignment statements' and give the role of each in computation. 10
- (b) In so far as they relate to a digital computer, explain the following briefly
- (i) the advantage of using binary number system
 - (ii) the function of a CPU
 - (iii) the use of fixed-point constant
- 10
- (c) Write a flow chart and write a FORTRAN program which can calculate and print the value of $\frac{2}{1}, \frac{4}{3}, \frac{6}{5}, \dots, \frac{22}{21}$, with an accuracy of 5 decimal points. 20

SECTION B

3. (a) Briefly describe the phenomenon of 'hunting' in a synchronous machine. How is it remedied? 10

- (b) A single phase transformer has percentage regulation of 4 and 4.4 for lagging power factor of 0.8 and 0.6 respectively. The full load copper loss is equal to iron loss. Calculate
- The lagging power factor at which full load regulation is maximum.
 - The full load efficiency at unity power factor.

20

- (c) Why are the compensating winding and the Interpole winding used in a universal motor for ac operation? Draw the schematic connection diagram of all the stator windings and the armature or an ac-operated series (universal) motor.

10

4. (a) Discuss the advantages and disadvantages of a nuclear power plant as compared to other conventional power plants.

10

- (b) A two-bus system is shown in Fig. 1. If 100 MW is transmitted from Plant 1 to the load, a transmission loss of 10 kW is incurred. Find the required generation for each plant and the power received by the load when the system λ is Rs 25/MWh.

The incremental fuel costs of the two plants are:

$$dF_1/dP_{G1} = 0.02 P_{G1} + 16 \text{ Rs / MWh}$$

$$dF_2/dP_{G2} = 0.04P_{G2} + 20 \text{ Rs/MWh}$$

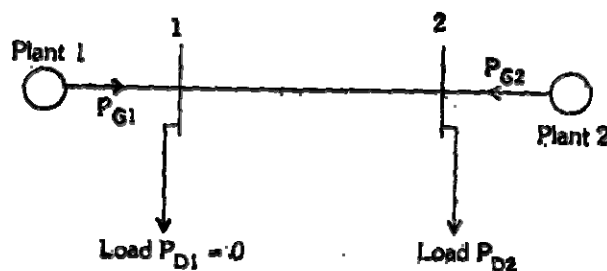

Fig. 1

15

- (c) With a neat diagram explain the distance relay protection scheme.

15

5. (a) Give the computational algorithm or a flow chart for obtaining swing curves using modified Euler's method.
- (b) The following test results were obtained on a 7.5 kW, 400 V, 4 pole, 50 Hz, delta-connected induction motor with a stator resistance of 2.1 Ω /phase.

No load	400 V,	5.5 A,	410 W
---------	--------	--------	-------

Rotor blocked	140 V,	20 A,	1550 W
---------------	--------	-------	--------

Obtain the approximate equivalent circuit model. Also estimate the braking torque developed when the motor running with a slip of 0.05. has two of its terminal suddenly interchanged.

15

- (c) Derive the torque equation of a dc machine.

10

SECTION C

6. (a) Sketch the time-domain response $c(t)$ of a typical under-damped second-order system to a step input $r(t)$. On this sketch indicate the following time-domain specifications:
- (i) maximum peak overshoot, M_p
 - (ii) rise-time, t_r
 - (iii) Settling time, t_s
 - (iv) steady-state error, e_{ss}
 - (v) delay time

10

- (b) The open-loop transfer function of a unity feedback system is given by

$$G(s) = K/s(Ts + 1)$$

where K and T are positive constants.

By what factor should the amplifier gain be reduced so that the peak overshoot of the unit step response of the system is reduced from 75% to 25%?

15

- (b) A unity feedback position control system has a forward path transfer function $G(s) = K/s$. For unit-step input, compute the value of K that minimizes ISI (integral square error).

15

7. (a) Give the relative advantages and disadvantages of the two graphical methods used in control systems e.g. Nyquist plot and Bode plot. State with reasons which you would choose for design purposes.

15

- (b) Determine whether the target time constant of the characteristic equation given below is greater than, less than or equal to 1.0 sec.

$$s^3 + 4s^2 + 6s + 4 = 0$$

10

- (c) Show that the system designed by

$$\begin{bmatrix} \dot{x}_1 \\ \dot{x}_2 \\ \dot{x}_3 \end{bmatrix} = \begin{bmatrix} 0 & 1 & 0 \\ 0 & 0 & 1 \\ -a & -b & -c \end{bmatrix} \begin{bmatrix} x_1 \\ x_2 \\ x_3 \end{bmatrix} + \begin{bmatrix} 0 \\ 0 \\ 1 \end{bmatrix} u$$

is completely state controllable for all values of a , b and c .

15

SECTION D

8. (a) Draw the circuit diagram of a C-MOS astable multivibrator and derive an expression for the period of oscillation.
- (b) Draw the schematic circuit diagram of a FET reactance modulator, explaining how frequency modulation is achieved with such a device.

15

- 10
- (c) Explain how an OP-Amp can be used as
(i) voltage follower (ii) RC - oscillator
- 15
9. (a) Draw the logic symbols and explain the operation of a D-type and T-type Flip-Flop.
- 10
- (b) Discuss with the help of a circuit example, the purpose of providing
(i) negative feedback
(ii) positive feedback in amplifiers
- 10
- (c) Explain the working of an emitter-follower and show how It performs the function of impedance transformation.
- 10
- (d) AMOSFET has a drain circuit resistance R_d of $100\text{ k}\Omega$ and operates at 20 kHz . Calculate the voltage gain of this device as a single stage amplifier. The MOSFET parameters are:
 $g_m = 1.6\text{ mA/V}$, $r_d = 44\text{ k}\Omega$, $C_{gs} = 3.0\text{ pF}$.
 $C_{ds} = 1.0\text{ pF}$ and $C_{gd} = 2.8\text{ pF}$
- 10
10. (a) Explain the principle of frequency modulation and its advantages over amplitude modulation for transmission of signals over communication channels.
- 15
- (b) The auto correlation function of an a periodic power signal is
$$R_{xx}(\tau) = \exp(-\tau^2/2\sigma^2) \quad -\infty \leq \tau \leq \infty$$

Find the psd and the normalized average power content of the signal.
- 10
- (c) Explain briefly the working of a PCM Communication system.
- 10
- (d) A signal $f(t)$ is band limited to $f_m\text{ Hz}$. What restriction will apply to the sampling rate needed for the faithful transmission of the squatted signal $f^2(t)$ in a time-division multiplexing scheme ?